

PRODUCTS/SERVICES LISTING

A

ABB INDUSTRIE AG

#924
Zurich, Switzerland

ADVANCED DYNAMIC CORPORATION LTD.

#938
St Bruno, Quebec, Canada

Advanced Dynamics Corp. Ltd. designs and manufactures custom materials handling systems for primary aluminum smelters and secondary aluminum products producers.

Primary Producers

- Carbon anode handling equipment for both green and baked anodes, rodding room and ring furnace maintenance equipment.
- Aluminum ingot sawing and identification equipment for round logs, T ingots and sheet ingots.
- Aluminum ingot handling systems including downenders, billet stacking systems, transfer cars and rotary turntables.
- Aluminum casting equipment including sow casting carousels and crucible filters.

Secondary Producers

- Coil handling equipment including turnstiles, powered transfer cars, wrapping systems and upenders.
- Tube handling cooling systems for drawbench automation, extrusion handling systems including pullers and flying cutoff saws.

Integrated Control Systems

- Computer linked PLC controls with panelview access screens, programmable identification by pin of character stamp, ink jet or bar code.

Please call us at your convenience to discuss your equipment requirements and visit us at booth #938 at the 1998 TMS show.



Inter Drawbench Cooling & Transfer System

AEA TECHNOLOGY

#1214,1216
Bethel Park, Pennsylvania

Materials and Chemical Process Assessment (MCPA)

AEA Technology has for many years had an extensive capability in both experimental and computational thermochemistry and kinetics. These skills have been applied to studying the detailed chemistry of a diverse range of processes for many customers, leading to improvements in process design and optimization, safety and environmental impact. Since 1992, these areas of chemical kinetics and thermodynamics have been integrated in a single product area, Materials and Chemical Process Assessment (MCPA).

MCPA brings together software, databases, consultancy, and experimental services and applies them to industrial problems associated with the kinetics and energetics of chemical processes and/or the determination of the concentrations and identities of species generated in processes. These processes can be studied for a wide range of materials, including metal alloys, ceramics, glasses, slags, aqueous solutions and vapor and aqueous phases either alone or in combination. Clearly, the scope of such studies is very wide and consequently MCPA has benefited a large number of customers in a broad range of industry sectors.

AGA GAS, INC.

#1108, 1110
Cleveland, Ohio

AIR PRODUCTS & CHEMICALS

#701 <http://www.airproducts.com/>
Allentown, Pennsylvania

Air Products and Chemicals, Inc. is a leading worldwide supplier of industrial gases and related technology. At TMS Exhibition '98, the company will feature its broad range of products and services that help customers increase their productivity and meet mounting environmental challenges. For example, Air Products will highlight its Ez-Fire™ Oxygen Combustion Systems for rotary, reverb, and sweat furnaces that enable customers to increase productivity, reduce melting costs, and reduce baghouse loadings. In operation at over 40 customer locations, the systems are easy to install and require minimal capital investment. The company also will showcase its industrial gas supply capabilities, ranging from on-site generation to cylinder supply, as well as ongoing applications and engineering support.

AIR PRODUCTS

AISCO SYSTEMS, INC.

#608, 707
Burlington, Ontario, Canada

Aisco Systems Inc. provides engineered machinery, systems and integrated process solutions for aluminium smelter rodding rooms, casthouses and copper tankhouses.

Rodding Room - Aisco is a technical leader in supplying rodding room equipment, from anode loading/unloading, butt bath cleaning systems, butt and thimble presses, and rod reconditioning equipment to anode and rod mating stations and iron pouring systems.

Casthouse - Aisco provides slab/T-bar/billet sawlines with fully automated material handling. Product inspection and packaging equipment is available to suit customer requirements.

Our automated foundry ingot casting, stacking and strapping equipment is designed and built for heavy duty use in primary and secondary facilities.

Copper Tankhouse - Aisco produces copper anode preparation and tankhouse machinery and solutions to your tankhouse problems. Our unique carousel design provides high production rates and efficient use of plant space.

Please call Aisco to discuss your equipment requirements or visit us at booth #608/707 at the 1998 TMS Show.



Fully automated aluminium billet sawline:



CAPTION: 2 & 3 PIN THIMBLE PRESS

**ALAN WORSWICK
(ENGINEERING) LTD.**

#907 <http://www.worswick.com>
Blackburn, England

Alan Worswick (Engineering) Ltd. was formed in 1960 and initially specialized solely in the design and manufacture of rotary - ingot casting machines.

Progressing from this, they moved into the field of automatic ingot handling with the conveyors, cooling baths, and ingot stacking machines to provide a complete, automated ingot production system.

As time passed, they received many enquiries and subsequent orders for specialized machines for the non-ferrous metal industry including billet stackers, anode producing machines, block/sow casters, lead dross removal machines, and automated gravity die casting machines, in fact, equipment to produce everything from zinc balls to aluminium engine blocks.

To date, Worswick has built more than 300 casters and 100 stackers and would be pleased to discuss your requirements at the 1998 TMS Annual Meeting & Exhibition at San Antonio, at our Booth No. 907.



ALCAN INTERNATIONAL LTD.

#1109, 1111
Montreal, Quebec, Canada

ALMEQ NORWAY AS

#822, 824
Langhus, Norway

ALTECH LTD.

#503
Reykjavik, Iceland

Altech provides engineering services involving feasibility studies, technical specifications and lay-out drawings for modification of anode rodding shops for aluminium smelters.

Altech manufactures also various innovative products and systems for improved environment, efficiency and economy, such as:

- Collar Mounting Machine
- Collar Filling Machine
- Stub Straightening Machine
- Graphite Coating
- Graphite Drying
- Casting Machine for Rod/Anode Sealing
- Rod Clamping Unit

Electrical Ladle Heater
Metal Skimming System



ALTEK INTERNATIONAL, INC.

#708 <http://www.altek-dross.com>
Exton, Pennsylvania

ALTEK International Inc. is the North American representative of HERTWICH ENGINEERING GmbH, manufacturer of Continuous Homogenization, Horizontal Casting, and Integrated Sawing Systems. Altek is also a designer, manufacturer, and supplier of aluminum dross recycling systems. "THE PRESS," the patented device for treating hot dross, maximizes the in-house recovery of metal and prepares the remaining dross for maximum recovery from the dross recycler. The system is environmentally clean, in most cases eliminating the need for a baghouse. "THE PRESS" is safe, easy to operate, has fast cooling cycles and low operating and maintenance costs. "THE PRESS" does not utilize compressed air, water or other costly gas additions. ALTEK offers additional recycling stems that treat the cooled dross.

ALTEK also has a joint venture agreement with DIDION Manufacturing Co., manufacturer of Dross Tumbling equipment for the aluminum recycling industry. The cold processing technology, "THE TUMBLER", further treats the dross, increases the in-house recovery, generates saleable by-products and other smaller fractions that require subsequent handling or land filling. Another TUMBLER system treats salt cake, recovering substantial amounts of metal.

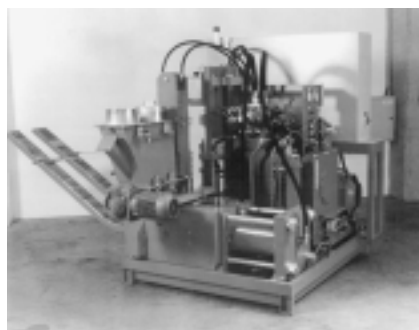
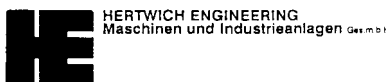

ALUCUT INTERNATIONAL

#505, 507
Katy, Texas

ALUMINIUM TODAY

#643
Redhill, Surrey, England

AMCOR

#1141, 1142
Medina, Ohio

AMERICAN COLLOID COMPANY

#942
Arlington Heights, Illinois

AMERICAN WELDING SOCIETY

#1035
Miami, Florida

The American Welding Society will present *D1.1-96 Structural Welding Code-Steel*, acknowledged worldwide as being a universal standard for assuring quality welding. Don't miss the *Welding Handbook*, the industry's indispensable reference (free with AWS membership). Literature on hundreds of other first-rate publications and 140+ ANSI-approved codes, standards, and specifications will be available. Information on the AWS Certified Welder and the Certified Welding Inspector programs, as well as on the benefits of AWS membership will also be accessible.

ANTER CORPORATION

#832
Pittsburgh, Pennsylvania

**APPLIED RESEARCH
LABORATORIES**

#1012
Dearborn, Michigan

ARL is the world leader for instrumentation that determines the chemical composition of aluminum alloys. The instruments are ideal for any operation from foundries to incoming materials control.

Designed for stability, reliability, and performances, ARL Models 2460 and 3460 Metals Analyzers provide cost effective analysis and turn-key operations.

The ARL Model 4460 Metals Analyzer combines leading edge technology, a current controlled source, (CCS) and time resolved spectroscopy (TRS), to significantly improve all areas of aluminum analysis.

All of ARL's Metal Analyzers embody critical success factors to meet the quality demands of today's market.

- Unmatched Stability and Reliability
- World Class Factory Calibration
- Speed and Accuracy
- Most Advanced Software Technology
- Advanced Technical/Service Support

ARL is dedicated to customer satisfaction by providing a distinct performance and value advantage for all quality operations.

ARBOR RESEARCH CORPORATION
#1033
Ann Arbor, Michigan

Arbor Research Corporation is the supplier of **OxyPure® on-site oxygen generators**. Combustion systems utilizing OxyPure® systems are the logical solution for complete oxy-fuel needs. The focus of Arbor Research is the complete solution to oxy-fuel combustion technology.

Utilizing Vacuum Pressure Swing Adsorption (VPSA) technology the OxyPure® systems are capable of generating oxygen from fresh air at a much lower cost than those of liquid supply contracts. The typical benefits experienced from oxy-fuel technology are significant increases in production, while at the same time reducing fuel usage and emissions.

We offer OxyPure® units capable of supporting up to 12,000,000 Btu/hr combustion systems. Together with combustion equipment suppliers, Arbor Research Corporation is able to offer the complete on-site solution to all oxy-fuel combustion needs.

Highlighted shall be all of the OxyPure® systems that Arbor Research has to offer, ranging from the small HE models up to the largest VPSA systems.



ASBURY FLUXMASTER OF UTAH, INC.
#742 <http://www.asbury.com>
Rodeo, California

Asbury Fluxmaster, a division of Asbury Carbons, produces and markets a line of high quality consumable foundry materials. These materials include a wide range of aluminum fluxes, titanium products, degassers, coatings, and injection fluxes.

Asbury Fluxmaster was added in 16 years ago as a division to our 100+ year old parent company to expand our historic strength into the non-ferrous metals market.

Asbury Fluxmaster offers customers the benefits of a professional, knowledgeable staff, a proven line of products, custom packaging options, and quality customer service. Asbury Fluxmaster products are marketed and sold in

the United States through our network of Territory Managers and distributors. Fluxmaster also has international agents and sales in over 20 countries.

Call Asbury or stop by booth #742 to give our professional staff the opportunity to impress you.

Our telephone number is (510) 799-3636 and our fax is (510) 799-7460 or visit our web page at <http://www.asbury.com>.

Asbury Fluxmaster	
<small>2855 FRANKLIN CANYON ROAD • RODEO, CA 94572 • (510) 799-3636 • FAX (510) 799-7460</small>	
FLUX & ALLOY INJECTION SYSTEMS	TITANIUM-BORON GRAIN REFINERS
FLUXES-DEGASSERS	INJECTION FLUXES
ENVIRONMENTALLY SAFE UNIFLUX	
 ASBURY <small>Founded 1895</small>	

ATAN SISTEMAS DE AUTOMACAO
#1128 (4 sp)
Belo Horizonte, Minas Gerais, BRAZIL

ATAN is today the largest Engineering Automation Company in Brazil.

ATAN built in 10 years a solid reputation as an automation solution provider in several industrial segments: aluminium, mining, cement, steel, ports, and food and beverage automation.

In 1998's TMS Meeting we will present the new release of SCORE, a complete solution for POT LINE automation, and TOP SCORE, a JAVA data collection module that exports production data to Intranet or Internet.

TOP SCORE's main idea is make information available to management levels using a regular browser like Netscape or Internet Explorer. The user situated in any part of the organization can mine the data, format tables and graphs, and print it in a desktop computer.

Today SCORE controls more than 1,900 pot cells and 500 000 tons of primary aluminium per year all over the world.

B

B&P PROCESS EQUIPMENT AND SYSTEMS

#1036
Saginaw, Michigan

B&P Process Equipment and Systems, LLC. (Manufacturers of Baker Perkins Machinery) is a supplier of specialized process equipment for the production of carbon pastes, energetic materials, plastics, industrial chemicals, solid waste pyrolysis, and chemical separations. In 1903, B&P supplied batch anode and cathode paste mixers for the first commercial aluminium smelter in the United States. As smelter began to increase in size, B&P evolved the initial tilt-type unit into a fixed bowl, bottom dis-

charge unit specifically for the production of carbon pastes, with the first unit being installed in 1935, which is still in service today. As the industry requirements continued to grow, B&P increased our offering in 1952 with the continuous carbon paste Polyneader®, which is being displayed at the 1998 TMS Annual Meeting Exhibition.



BETZ/DEARBORN WATER MANAGEMENT GROUP

#834, 836, 838
Trevose, Pennsylvania

BetzDearborn Water Management Group markets engineered water treatment programs that use customized products and value-added services in solving problems associated with boilers, cooling towers, and influent and effluent systems in a wide variety of industries, commercial establishments, and institutional facilities. Hundreds of BetzDearborn researchers simulate the operation of a water system, troubleshoot, and isolate problems in one of the largest water research facilities in the world.



BHA GROUP, INC.

#1004
Kansas City, Missouri

BHA Group, Inc. is the global leader in air pollution control replacement parts and services for baghouses, electrostatic precipitators, and evaporative gas conditioning equipment. The BHA philosophy of problem solving and innovative product design have positioned the company as the world's leading single source supplier for air filtration parts and services. All of BHA's manufacturing facilities in the United States are ISO 9001 or 9002 registered. This ensures customers that BHA's quality systems meet or exceed standards accepted around the world.

BHA is the world's leading supplier of parts, engineering systems, and troubleshooting services for fabric filter dust collection (baghouse) equipment used in many industries. To meet the most demanding air filtration efficiency needs, BHA manufactures fine filtration products, including pleated filter elements (with two to three times more surface collecting media than traditional bags) and filter media laminated with BHA-TEX®, an expanded microporous PTFE membrane (providing up to 99.99+% efficiency).



BLASCH PRECISION CERAMICS

#1037
Albany, New York

BLOOM ENGINEERING CO., INC.

#801
Pittsburgh, Pennsylvania

Bloom Engineering Company, Inc. designs and manufactures burners, controls and combustion equipment for the aluminum, other non-ferrous and ferrous industries.

Representatives from Bloom will be available to discuss Bloom's complete burner line including Fuel Energy, high intensity and regenerative burners as well as their application to various furnaces used in the industry. Featured at the show will be Bloom's recently introduced LumiFlame and Regenerative HTR (Flat Profile Flame) burners. Measured NOx values from Bloom's complete line of Ultra Low NOx regenerative and conventional burners are the lowest in the industry.

BMI/France HEPWORTH REFRACTORIES

#1322, 1324
Carnegie, PA

BMI-France Hepworth Refractories has a complete line of products to service the aluminum industry. Our Alu-Dri line of non-wetting materials has been proven to provide excellent resistance to molten aluminum penetration. This line consists of non-wetting low-cement vibratable and pump castables, insulating castables, plastics, gunning materials and brick to effectively construct and maintain all molten aluminum melting/holding furnaces and ladles.

BMI-France SurShot Process Technology blends the properties of low-moisture and low-cement castables. The resultant wet-mix is processed through a pneumatic pump and specially designed shotcrete nozzle for placement. The SurShot process reduces equipment downtime and increases installation reliability.

BNZ MATERIALS, INC.

#1315 <http://www.ceramics.com/bnz/>
Littleton, Colorado

BNZ Materials, Inc. consists of two businesses which are appropriate to the metals industry. The Zelienople, Pennsylvania plant manufactures/markets Insulating Firebrick and complementary refractory products such as mortars, aggregates, castables and calcium silicate block. Insulating Firebrick are used in a variety of applications in the metals industry, from carbon baking furnaces to melting and holding furnaces.

The Billerica, Massachusetts plant manufactures a line of calcium silicate boards under the Marinite® trademark. They are machined into various parts for conveying, containing, and forming aluminum, lead, zinc, tin and other

non-ferrous metals. These parts include spouts, floats, launders, distribution plates, head boxes, baffles, headers, tips, rings, distribution boxes, stoppers, basins, snouts, orifice plates, hot top and ingot mold liners as well as parts in the metal handling and casting systems of many casting machines.



BOMEM INC.

1114, 1116
Québec, Canada

Bomem offers advanced analytical instruments for the characterization of aluminum melts.

Four different inclusion measurement techniques are available:

- LIMCA II for in-line inclusion counting and sizing in the range of 20 to 300 micrometers.
- PoDFA for off-line quantitative and qualitative inclusion characterization, providing the total inclusion content, broken down by types of particles.
- Prefil®-Footprinter for at-line inclusion quantification. It records the filtration rate curve during a standardized filtration test and compares it with pre-programmed information that enables you to see the quality of the liquid metal.
- QUALIFLASH® for aluminum oxides. With this shop instrument you can evaluate the melt quality of foundry alloys within 20 seconds at a very low cost.

Hydrogen measurement with three different models of the AISCAN™ analyzer are available:

- AISCAN™ C for Casthouses
- AISCAN™ F for Foundries
- AISCAN CM for Continuous Monitoring



BRANDT FILTRATION GROUP

#1230, 1232
Norcross, Georgia

Brandt Filtration Group specializes in the capture of dusts and fumes from hot process gases. Applications include control of primary and secondary emissions from a variety of metallurgical processes, as well as emissions from power generation and cement production.

Products range from modular pulse jet and reverse air baghouses to complete turn-key emissions abatement systems handling gas volume well over one million ACFM.

Brandt supplies baghouses utilizing a variety of fabrics and different materials of construction as site specifics dictate.

BROCHOT scs

#1129
Tremblay en France, France

BUEHLER LTD.

#1003
Lake Bluff, Illinois

Buehler will display its new Omnimet Enterprise image analysis system. This high resolution (1260x960 pixels) system uses 32 bit software running on Windows 95 and is available in either black and white or color cameras. System hardware includes 233 Mhz Pentium II PC, 17" monitor, CCD camera, frame and grabber, and software.

We will also display the Buehler M.A.R.S. NT (Materials Archive and Report System). This is a newly improved Windows NT-based, 24 bit, full color system that offers exceptionally versatile archiving and retrieval capabilities. As an integrated package the M.A.R.S. System combines image archiving, report generation and new image measurement functionality within a user friendly environment.



BUSS, A.G.

#1014
Prattein, Switzerland

BUSS A.G. Basel, Switzerland are the leading supplier of Anode-Paste production lines. In view of the present situation at the world primary aluminum market it is very obvious that new ideas and methods are required for improving the cost benefits.

Small things can be important and can make or break the business. Consequently, BUSS A.G. has introduced the inline BUSS-Tandem system for mixing and kneading of the paste for prebaked anodes, as well as under consideration of the renaissance of the Russian aluminium industry, also the improved production of Soederberg-paste with the ddry-process. Do not waste your cast, contact us at our booth or elsewhere. We are pleased to negotiate with any interested party the tailor-made possibilities for improving the production of anode paste, either with existing or new installation. Our knowledge is your cost benefit.

BWE LTD.

#902
Ashford, Kent, England

The latest advances in Conform and Conklad technology will be on show including several examples of bi-metallic products

recently developed at BWE's new research and development centre. The range of wire and cable produced offering unique advantages when manufactured with BWE's Conform/Conklad system continues to grow... from rectangular wire requiring no cleaning or annealing before covering in insulation, to fibre optic cables which can be made in very long lengths (theoretically infinite but typically 10-15 km). Also on show will be examples of aluminium extrusions including the aluminium sheathing of flexible cores (CATV, fibre optics etc), the aluminium sheathing of solid cores (steel wire, steel tubes etc), aluminium tubes, strips and sections.

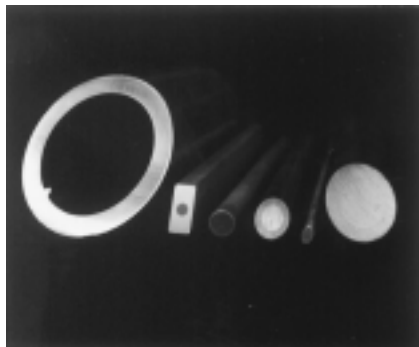

C

CANADIAN HOPEWAY INDUSTRIAL MINERALS CORP.

#1321 <http://www.intergate.bc.ca/business/hopeway>
Burnaby, British Columbia, Canada

Canadian Hopeway Industrial Minerals Corporation is a Canada-based company with mining properties, processing plants and laboratories in China. Acting both as a producer and trader, we aim at selling our quality goods at competitive prices.

PRODUCT RANGE:

- Abrasives, Refractory & Ceramics Minerals:
 - Barytes
 - Garnet
 - Graphite
 - Kaolin
 - Olivine
 - Quartz
 - Strontium
 - Talc
 - Tungsten
 - Zeolite
- Rare Earth & Rare Earth Alloys:
 - Cerium Metal & Rare Earth hydrate
 - Lanthanum Metal
 - Rare Earth Ferrosilicon Alloy
 - Rare Earth - Ca, Ca-Mg, Cu-Mg, Mg, Mn-Mg, Ti-Mg, Zn-Mg, Ba-Ca-Mg Ferrosilicon Alloys

OTHER SERVICES:

- China Project Consulting & Financing
- Import minerals to China and market new & used mining equipment

Contact Details: Max NG, Marketing Director, 9912 Lougheed Highway, Burnaby, BC, Canada V3J 1N3
Tel: (604) 421 6989 Fax: (604) 421 7622
Email: hopeway@intergate.bc.ca

CAST HOUSE TECHNOLOGY LTD.

#536
Quelph, Ontario, Canada

Cast House Technology specializes in hot metal handling and metal treatment systems. In particular in line trough degassing equipment, and pulsed water cooling technology for controlling butt distortion in heavy sheet ingot. Featured at the TMS exhibition are the Cast House Submerged Jet Trough Degassing Reactor and the Cast House Pulsing Valve.

CHINESE SOCIETY FOR METALS

#1207
Beijing, China

The Chinese Society for Metals (CSM) which is a nationwide organization engaged in the promotion of science and technology in the field of metallurgy and materials was founded in 1956. Under the auspices of CSM, there are professional institutes/committees, working committees and local chapters responsible for science, technology and professional activities respectively connected with mining, metallurgy, materials science and engineering, and other relative fields through the following aspects:

- Organize the experts to offer the national government departments relative consultant and proposals about economical and technical development of the metallurgical and materials industries
- Hold domestic and international symposia and conferences
- Publish books and periodicals
- Promote technology exchange and consulting services
- Continuous education and training

CLEMEX TECHNOLOGIES, INC.

#735
Longueuil, Quebec, Canada

Clemex Technologies, Inc. is a leading developer and marketer of image analysis and management systems for use in quality control and R&D labs. The company offers a family of turnkey systems and application specific software modules designed to facilitate quantitative microscopy. Through highly intuitive and automated integrated systems, Clemex Technologies gives labs a greater competitive advantage by dramatically improving archaic image analysis and archiving processes. At the

heart of each system is Clemex Vision - a robust, all-purpose image analysis software application.

Clemex will be exhibiting its Clemex Impak system along with Clemex R'Kive - a scientific image archiving and management package.

COBALT DEVELOPMENT INSTITUTE

#635
Guilford, Surrey, England

The CDI is the world association for all those engaged in cobalt's multi-faceted world. Production, extraction, refining, converting, chemical preparation, trading. It also covers the many end-uses from superalloys to catalysts, battery additions, cemented carbides, diamond tooling, tyre adhesives, paint driers, hard facing alloys, dental alloys, and many others.

The CDI will be exhibiting information on many of these subjects and staff will be available to answer your questions and supply further information. A full range of CDI literature will also be available.

CONSOLIDATED CERAMIC PRODUCTS, INC.

#813, 815
Blanchester, Ohio

For 40 years, Consolidated Ceramic Products has been of service to the aluminum industries worldwide. An innovative manufacturer and marketer of ceramic based products, it maintains operations in Cincinnati, Ohio and Sheffield, England with distribution points around the world.

CCPI products and services for temperature measurement, chemical modification and physical transport of molten aluminum include:

- Ceramic coated alloyed cast iron thermocouple protection tubes.
- Mineral insulated and plasma beaded, ceramic insulated thermocouple elements.
- ACCUTIP Dipping thermocouples.
- Ceramic coated fluxing pipe, available with gas diffusing media.
- Ceramic coated alloyed cast iron riser stalk tubes.
- Vacuum formed fiber tapout cones with matching cast iron plugs.
- Radiant and immersion heaters and replacement elements.
- Thermal profiling services for aluminum melting, holding and heat treating furnaces.
- High technology SIALON thermocouple protection tubes, level sensors, riser stalk tubes, heater tubes, and special shapes.
- Aluminum Titanate riser stalk tubes, sprues and break rings.
- Custom cast iron castings such as transfer troughs, air and water cooled pig molds, flow devices, and crust plungers.
- Impellers, shafts, rotors, nozzles, baffles and pre-cast liners for degassing and filtration systems.

Consolidated Ceramic's team of sales, mar-

keting and technical personnel provides unparalleled service to the aluminum industry; we invite you to come and meet us.

pick-up from page A-4
Nov 97 JOM

CONTROL VISION INC.

#941
Idaho Falls, Idaho

CORMAN BAG COMPANY

#906
Chelsea, Massachusetts

Corman Bag Company sells multiwall paper, polyethylene and woven polypropylene packaging to hold 25, 50 & 100 lbs of product. We concentrate on the packaging of free flowing granulars, powders and flakes. Additionally we sell the weighing, placing, conveying, closing, & palletizing equipment needed to handle the bags. We look for the unusual situation, the highly technical problem, the fanciest accessory - wherever we can add our expertise to your bag.

D

DOALL COMPANY

#1100
Savage, Minnesota

E

EBNER FURNACES, INC.

#638
Wadsworth, Ohio

Ebner Furnaces, Inc. and Ebner Industrieofenbau will display the latest technology related to high performance furnaces for the aluminum industry. Of particular importance are the roller-hearth furnace for solution heat treating aluminum plate and pusher type furnace for re-heating and homogenizing aluminum ingots. The photo below depicts one of eight (8) furnace modules of a roller-hearth furnace that was shipped to a mid-western aluminum producer, from our manufacturing facility in Wadsworth, Ohio. Ebner also supply equipment for solution heat treating and aging of aluminum castings and extrusions and batch type annealing ovens for aluminum strip coils and aluminum foil.



EIRICH MACHINES

#929
Gurnee, Illinois

Eirich Machines, Inc. of Gurnee, Illinois, is a manufacturer of mixing and pelletizing equipment for the ceramic, metallurgical and other industries.

The famous Eirich Intensive Mixer, well known for the excellent mix quality it produces, its energy efficiency and its durability, can be configured for batch or continuous operation. It is available in a variety of different sizes from lab mixers to large capacity production units suitable for most industrial requirements.

Eirich also offers disc pelletizers and mix/pelletizers for the manufacture of granules made from dry solids only or sludge with dust. The mix/pelletizer combines both the mixing and the pelletizing processes within the same piece of equipment thus saving space and reducing the initial investment.

Supporting equipment includes a wide variety of metering, weighing, conveying and discharging systems, as well as superior control and process data technology for fully automated processes.



ELSEVIER SCIENCE

#1029 <http://www.elsevier.nl>
New York, NY

ERICO, INC.

#1314, 1316
Solon, Ohio

ESM SOFTWARE

#908
Hamilton, Ohio

ESM Software will exhibit a large collection of materials science software covering materials properties, thermochemistry, crystallography, and materials processing. Products include

version 3.0 of TAPP, a database of thermophysical properties of pure compounds; MAPP, a database of properties of engineering alloys and polymers; ChemSage and HSC Chemistry for calculation of complex phase equilibria; IceNine phase diagram drawing software; metal and ceramic phase diagram CD-ROMs; and crystallography databases and crystal drawing software. Most of the software packages can be previewed at <http://www.esm-software.com> and <http://www.materialize.com>.

EXAKT TECHNOLOGIES, INC.

#1201
Oklahoma City, Oklahoma

EXPLORANIUM

#1042
Rio Rancho, New Mexico

F

FCB

#900
Givors Cedex, FRANCE

THE FEDERATION OF EUROPEAN MATERIALS SOCIETIES

#538
Frankfurt, Germany

FEMS is a European not-for profit organization representing 18 Materials Societies in 16 countries. Its general aims are to promote a wider understanding of the economic importance and the potential of materials by facilitating and encouraging a closer coordination of the activities of its member societies and related bodies. Its conference activities comprise a biennial congress EUROMAT covering a broad range of materials subjects, EUROMAT Topical conference and Junior EUROMAT, a biennial conference especially designed for young materials scientists. Member news and general European news are published in EUROMATERIALS, a quarterly newsletter.

FIEDLER OPTOELEKTRONIK GMBH

#1202
Luetzen, Germany

Fiedler Optoelektronik GmbH is a technology oriented company in Germany. Main activities of a creative team of engineers and technicians are development and production of laser optical systems for material testing, process control, and security and safety applications.

Material testing:

We are specialized in the determination of the local and integral strain behavior in tensile tests or related experiments by means of laser extensometers. With one single device we can measure, free of contact, the strain distribution over the surface of a specimen from the elastic to the plastic behavior up to the rup-

ture.

Process control:

We offer Laser-Doppler-Velocimeter to determine non intrusively and continuously the velocity of a strand or profile and Laser scanners to determine the diameter simultaneously.

Security and safety:

We manufacture extremely extended laser light curtains to detect invading objects.

In addition to our modular standard systems we provide measurement solutions tailored to the need of the customer.



FOSECO, INC.

#722

Cleveland, Ohio

FOSECO, INC. manufactures products and provides services for casting aluminum throughout the world. Foseco's recent purchase of the SNIF[®] business from Praxair, Inc. enables Foseco to bring a full line of products for in line processing of molten aluminum to our customers. SNIF degassing equipment and technology is recognized as the world's market leader.

FOSECO'S TILITE[®] grain refiner is widely used for foundry ingot. FOSECO'S FILTREX[®], a sintered, phosphate-free composition, is a premium ceramic foam filter offering new advantages to our customers. Through a worldwide distributor agreement with Metallurgics, Inc., FOSECO offers molten metal processing equipment such as pumps and the Metallurgics Cartridge Filter, a high-efficiency bonded particulate filter for critical aluminum applications. Premium refractory materials for molten aluminum filtration and casting are supplied by FOSECO as well. FOSECO can provide engineering and metallurgical services for molten aluminum processing as required by our customers.

FOSECO is committed to helping improve the business performance of our customers.

G

GCD INTERNATIONAL PTY LTD.

#936

Website: www.gcd.com.au

Knoxfield, VIC, Australia

GCD are leading suppliers of combustion and process equipment to primary aluminium smelters and will be featuring:

- A unique Pot Bake Out system jointly developed by Comalco and GCD and exclusively licensed to GCD for worldwide distribution. The system now operating widely in Australia, New Zealand and South America offers extremely even heat up, and is predicted to extend pot

life to both Pre Bake and Sodaberg cells.

- Anode Stub Coater using electrostatic spraying of graphite to ensure even, dust free and highly efficient coating contributing to the quest for constant improvement in cell efficiency.
 - A range of crucible driers and preheaters
 - Siphon tube driers/heaters and melt out furnaces
 - Stub driers/preheaters
 - Cathode collector bar heaters
 - Anode driers
 - Fluidised Bed Heat Treatment Furnaces and Patented Hard Coating Processes based on Borides, Carbides and Nitrides.
- Contact: Mr Richard Jones
Phone: +613 9764 1733
Fax: +613 9764 1523

GILLESPIE & POWERS, INC

#600

St. Louis, Missouri

- Furnace upgrading and modification—improving efficiency, melt rate and pollution control.
- Sow preheating with our patented reverse flow melter.
- Decoating with our patented mass flow recirculation system, all types of scrap.
- Controlled variable scrap feed systems for conveying, submerging, and salt feed. Two styles of submerging devices.
- Unique designs to resolve specific problems—eliminate water cooling, sealed charging, flat removable roofs, low profile doors and others.
- In the recycling industry, systems include bale breaking, shredding, separation, decoating, vortex submerging, melting and holding furnaces including rotary furnaces, and transport ladles.

GLAMA MASCHINENBAU GmbH

#808

Gladbeck, GERMANY

GLAMA has designed and built heavy-duty Mobile Equipment for Aluminum pot rooms, cast houses and anode rodding shops throughout the world for nearly 30 years. The following types of mobile equipment are available:

- Anode Changing Vehicles
- Hammer Crustbreakers
- Tapping Trucks
- Anode Pallet Haulers
- Furnace Charging Machines
- Furnace Tending Machines
- Mobile Flash Gas Refiners
- Ladle Charging Trucks
- Molten Metal Carriers
- Butt Cleaning Manipulators
- Coil Lift Trucks

GLAMA's experience of many years of producing machines with a unique combination of advanced control and rugged, reliable construction is evident in the several hundred

machines now in service. GLAMA equipment withstands the heat, dust, vibration and battering of heavy industry while delivering precise handling performance.

The GLAMA booth at the TMS Exhibition will feature the latest developments: new Molten Metal Carrier with 50,000 lbs. lift capacity and a brand new generation of Anode Pallet Haulers.

A.P. GREEN INDUSTRIES, INC.

#831, 833

<http://www.apgreen.com>

Mexico, Missouri

H

HAMILTON RESEARCH & TECHNOLOGY

#927

Calcutta, WB, India

Hamilton Research & Technology (HART) a high technology company, in association with Indian and European Aluminum Reduction Specialists, offers fully distributed Process Control Systems to aluminum producers.

HART's systems based on microprocessor/DSP technology, have evolved in sophistication and user friendliness. HART's software experts refine user interface to icon based screen obviating the need for computer literacy.

HART has supplied to HINDALCO, one of the lowest cost and most profit making aluminum producer, a network of pot controllers connected to a supervisory computer system with fibre optic backbone. The system successfully controls nearly 1100 pots. HART has also supplied Heating & Regulation System for Carbon Anode Baking Plants of NALCO, the largest aluminum company under Government of India.

HART has an impressive customer list which includes end users like aluminum smelters, steel/cement plants, railway & defense departments, and OEMs like switchgear manufacturers and networking companies spread over North America, CIS, South Africa and Asia.

HATCH ASSOCIATES LTD.

#1005, 1007

Mississauga, Ontario, Canada

Hatch Associates is an employee-owned international consulting and engineering company that provides comprehensive services to the metallurgical industry worldwide.

The company is particularly well-known for its work in the planning and execution of projects involving the scale-up of process technology through engineering, construction and start-up.

The company provides services in the following fields:

- Non-ferrous Metals
- Light Metals
- Industrial Minerals
- Iron and Steel

Consulting to Management
Resource Recovery and Recycling

Activities in the field of Non-ferrous metals include mining, mineral processing, pyrometallurgy, hydrometallurgy, custom-design of various types of smelting and other process furnaces, and associated environmental assessments, design, permitting and construction.

General services include conceptual and feasibility studies, capital and operating cost estimates, detail engineering, engineering, procurement and construction management (EPCM), commissioning and start-up.

Clients are served from 20 permanent offices in the USA, Canada, England, Poland, Czech Republic and South Africa.

HENCON B.V.

#1428
Gendringen, The Netherlands

Backed by more than 40 years experience, Hencon Holland is a main and worldwide supplier in the field of special Mobile Equipment for the aluminum industry.

The delivery program covers the complete range for potroom (Söderberg and prebaked) and for the casthouse.

Potroom equipment:

- Anode Pallet Transporters
- Ladle Transport and Tilting Vehicles
- Tapping Trucks
- Vacuum Cleaners
- Vacuum Systems
- Alumina Feeders
- Anode Covering Vehicles
- Anode Briquette Feeders
- Crust Breakers
- Bath Cleaning Machines
- Combined Feeding Trucks
- Anode Changing Machines
- Rack Raising Trucks
- Spading Machines
- Pot Skimming Vehicles

Casthouse equipment:

- Furnace Skimming and Cleaning Machines
- Furnace Charging Machines
- Ladle Transporters
- Sideloaders

Recent developments, like a new design of Crustbreaker and Cavity Cleaner will be shown at the TMS Exhibition.



HERAEUS ELECTRO-NITE COMPANY

#702, 800
Philadelphia, Pennsylvania

Heraeus Electro-Nite Co., the world's largest developer and producer of sensors for the molten metal industry, will be exhibiting several recently developed sensors for the primary aluminum smelter.

The Cry-O-Therm™ "Superheat" sensor has been developed to provide the potline with an almost instantaneous reading of the bath and liquidus temperatures. It is being shown that direct measurements of the liquidus temperature in industrial cells by the Cry-O-Therm probe is clearly advantageous compared to the alternative methods for determining the liquidus temperature.

The Positherm-AL® Type "S" disposable thermocouple and DT-280 digital temperature measuring system provide the potroom operator with a faster, more accurate, and more reliable temperature of the cryolite bath. The companion datalogger allows the operator to store the information collected over the course of the day and download it directly into the computer at the end of his shift.

Stop by the HEN booth to learn more about our new sensors for the primary aluminum smelter.

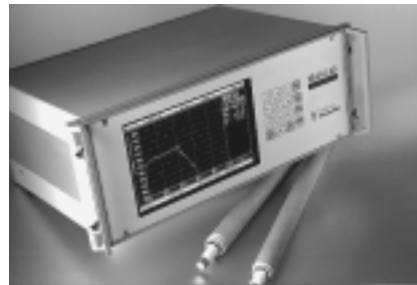

HIGH TEMPERATURE SYSTEMS, INC.

#604
Chagrin Falls, Ohio

A Complete Source for Molten Metal Pumping Solutions

High Temperature Systems Inc has provided solutions for molten aluminum and zinc applications for over 25 years. For Circulation and Transfer we offer a large range of pump sizes and flow rates, catering to the specific production needs of our customers.

High Temperature Systems Inc. is introducing new products that are solutions to old in-

dustry issues. Our Quality Committee offers our customers assurance that they are receiving quality products. We are continually setting new goals in research and development, finding new ways to improve customers' production with cost efficient solutions.

We are committed to our customers and building the relationships we have established, and growing with new customers in the future. For more information about our products and services, visit our Web Site at www.hitemp.com

High Temperature Systems • 6755 Park Circle
Chagrin Falls Ohio 44023 • Telephone: 440/
543-8271 • Fax: 440/543-8198



HI-SCOPE SYSTEMS COMPANY

#1338
Closter, New Jersey

HI-SCOPE SYSTEMS is the first 3-D Image video microscope for observation and visual inspection of materials and components. Unique 360 degree rotary viewing provides superior resolution and great depth of field, perfect for quality control, failure analysis, and research development. HI-SCOPE can be connected to a video printer, VCR, or PC for documentation, image analysis, and measurement. Magnification range from 5X to 600X for 3-D rotary viewing and up to 2500X for straight viewing.

HODGES GROUP, INC.

#1243
Portland, Tennessee

Hodges Group, Inc. is a family owned and operated company specializing in turnkey solutions for construction, industrial maintenance, fabrication and refractory projects. We are the recipient of the "Industrial Excellence Award" from the Tennessee Department of Economic and Community Development and are one of Tennessee's fastest-growing companies with a reputation for service and excellence.

We offer a wide range of products and services to meet the individual needs of our clients, whether it's the construction of a solid waste landfill or furnace installation and main-

tenance. We are experienced and fully equipped to meet the highly specialized application needs of high-temperature equipment and manufacturing processes. For a complete description of our services, please visit our website at <http://hodes-group-inc.com>.

Tel: 615-325-2741 Fax: 615-325-3128 E-mail: hodes@hodes-group-inc.com

HÖGANÄS ELDFAST AS

#1228
Fjellhamar, Norway

HÖGANÄS ELDFAST AS is part of the Höganäs Eldfast group of companies originating in Sweden and dating back to the 19th century. We supply "complete packages" of refractories and acid resistant material- from design to products, contracting and service.

Our fast, easy to install pot barriers, layer-and-sidewall refractories. BJUF S, DENSCAST 50, and ladle castable ALKON have been very popular in the aluminium industry for many years.

Now, at last, we can meet demands to reduce pollution and harmful dust in the production environment and, at the same time cut installation costs with our unique new product DRYCAST. DRYCAST is a ready-to-use vibratable mix for electrolytic pot lining. It flows easily into all corners, forming an even smooth surface of high penetration and slag resistance and minimal porosity in less than 30 minutes.

If you are looking for better working environment, improved economy and productivity, and no dust!. Welcome to HÖGANÄS ELDFAST AS, Booth #1228.

HOLCAN CONSTRUCTIONS PTY LTD.

#1423
Queensland, Australia

The Holcan Welding System offers an alternative to hand, friction or flat butt welding of anode rod stubs and adds a degree of automation at a low capital cost.

Our system will outperform manual welding methods by up to 60%.

Simplistic design and proven reliability allows for in-house maintenance to be carried out on all pieces of equipment therefore eliminating the need for technical assistance from outside sources.

*pick-up from page A7
Nov. 96 JOM*

HOLTON/CONFORM

#703
West Howe, Bournemouth, United Kingdom

Holton Conform produces machines and complete lines for the continuous extrusion of nonferrous metals. At TMS '98, Holton is presenting this technology and its applications for

manufacturing aluminum solids, tubes and sheathing/cladding operations.

Grain Refining Rod:

Holton's technology is used to manufacture aluminum grain refining rod. The coiled rod has no discontinuities, a homogenous distribution of grain refining elements and a bright finish.

Solid Conductors:

Holton Conform extrudes solid aluminum conductors including sector shapes.

Round and Multiport Tubing:

Holton Conform is capable of direct extrusion of heat transfer tubing with consistent mechanical properties, no perforations and no surface lubricants.

Reprocessing Scrap:

Holton has developed technology to accept granulated aluminum, including process scrap, converting it directly into products such as steel deoxidizing rod without melting.

Sheathing of Cable Cores:

Holton's sheathing lines extrude seamless aluminum tubes around cable cores including fibre optics units (OPGW) and coaxial RF cables (CATV).

Cladding:

Holton's lines are used for the continuous aluminum cladding of steel wires and aluminum stabilizing of superconductor cable cores. Holton Conform and its customers are supported around the world by its parent company, Outokumpu.

HORIBA INSTRUMENTS

#842
Irvine, California

Horiba Instruments manufactures a broad line of analytical instrumentation used for environmental monitoring and testing for research and QC laboratory applications.

Horiba will be exhibiting its full line of particle characterization instruments, including:

1. Light Scattering Particle Size Analyzers with a range of 0.02 to 2000 microns with an optional dry powder feeder and autosampler.
2. Surface Area Analyzers with automatic calibration and zeroing for maximum repeatability and accuracy.
3. Centrifugal Sedimentation Particle Size Analyzers with a range of 0.03 to 300 microns for fast and economical sedimentation analyses.
4. Gas Pycnometers for measuring true density/volume of particles.



HOSOKAWA MICRON GROUP

#836 <http://www.hosokawamicron.com>
Summit, New Jersey

HOTWORK CORPORATION

#1416
Lexington, Kentucky

Refractory Dryouts and Heatups

Since our inception in 1965, Hotwork Corp.'s highly trained and experienced technicians have serviced over 10,000 job sites in all continents. Our reputation for performing refractory dryouts and heatups of furnaces is second to none.

Hotwork Corp. is the pioneer of the convective heating process, which simplifies refractory dryouts and heatups. With our help, you get into production more smoothly.

The application has been particularly beneficial for the aluminum industry where we introduced the concept in 1974. We were able to reduce the heatup from the traditional fourteen(14) days to an average of four (4) days or less. That was almost 1,000 furnaces ago.

Need professionals to bring your furnace on stream? Contact:

Hotwork Corp.
223 Gold Rush Road
Lexington KY 40503
Tel: 606/276-1570
Fax: 606/276-1583
E-Mail: hotwork@worldnet.att.net

HYDRO ALUMINUM HYCAST

#912 (6 spaces)
Sunnalsøra, Norway

HYSITRON, INC.

#1311
Minneapolis, Minnesota

In 1995, Hysitron, Inc. introduced to the global community an instrument specifically designed for precise nanomechanical activity at the atomic level. The ability to touch the atomic surface, and then exactly control the force in which you move in dimensions, one atomic level at a time, offering tremendous new opportunities of investigation of new materials.

Hysitron, Inc. manufactures nanomechanical testing instruments especially tailored for the measurement of hardness, elastic modulus, friction, scratch, and wear of thin films. The TriboScope (registered) offers the materials scientist the unique ability to perform quantitative nanoindentation and nanoscratch testing with in situ atomic force microscopy imaging.

INDUSTRIAL HEATING MAGAZINE

#1043

Pittsburgh, Pennsylvania

IPI (INDUSTRIAL PRODUCTS INTERNATIONAL)

#502

Englewood, Colorado

IPI will feature its line of Q-Bloc ceramic shapes in the form of downspouts, nozzles, control rods, ladles, casting tips, troughs, filter bowls, and riser tubes used in the molten metals processing industry. Complimentary products include Q-Bloc NR non-respirable fiber products for use to 2000F, calcium silicate boards and machined parts.

New for 1998 is a line of vacuum formed fiber products.

IPI not only offers products but also assistance in designing and installing your casting system.

INNOVATIVE CONCEPTS

#1211

Richland, Washington

The U. S. Department of Energy's Office of Industrial Technology and Office of Transportation Technology are sponsoring aluminum and titanium related technologies through the Innovative Concepts program. The concepts address innovations in aluminum and titanium production, waste minimization, and fabrication. The program sponsors technologies that are novel and innovative, providing seed money, commercialization strategy guidance, and preliminary promotional assistance to introduce the concepts to industry for consideration for further development and eventual incorporation into the processes. The technologies are breakthrough technology or novel uses of current technology and will likely require additional development and industrial guidance, but will introduce technologies that may be utilized in the future by the aluminum and titanium industries.

DEPARTMENT
of ENERGY
**Innovative
CONCEPTS**

JAYNE INDUSTRIES INC

#1421

Stoney Creek, Ontario, Canada

**JERVIS B. WEBB
WORLDWIDE COMPANY**#1328, 1427 <http://www.jervisbwebb.com>

Farmington Hills, Michigan

The Jervis B. Webb Company has more than 75 years of experience in managing, producing, and installing large-scale integrated material handling systems. Today, Webb material handling systems move products and materials in almost every industry. The management and staff of the Jervis B. Webb Company are dedicated to maintaining our leading market position within the material handling industry by applying 100% of our efforts toward one product: custom engineered material handling systems.

Webb's experience in the Aluminum Smelter industry includes furnishing material handling equipment and systems for several large aluminum companies. Because of the Webb Company's diversity in the material handling field, many systems have been engineered and installed in different areas of aluminum operations.

Included in these installations are several Power & Free Systems for Rodding Rooms, with the most notable being for Kaiser, Alcoa, Alcan and Intalco. Power & Free systems offer many advantages for the handling operations involved in rod processing for butt return to delivery of the rod anode.

K**KB ALLOYS, INC.**

#509, 511, 513

Reading, Pennsylvania

Since its founding in 1950 as the Kawecki Chemical Company, the name KB Alloys has been synonymous with innovation and leadership in the aluminum master alloy industry. Many of today's industry standards—metallurgical grain refiners, including TIBOR®, TITAL® and TICAR®, waffle ingot and rod, along with countless chemistry advances—number among KB Alloys' "industry-firsts."

The company has always been guided by a philosophy of growth through a commitment to research, technical development and high-quality products.

TIBOR®, TICAR® and TITAL® master alloys are used for grain refinement to deter cracking in the ingots when casting and to improve casting speeds. BORAL® master alloy is used to improve conductivity, beryllium to minimize magnesium burn off, and strontium to modify the silicon phase in foundry alloys. Hardener alloys are used to improve mechanical and physical properties. MULTIPLEX® alloys provide an effective method for simultaneous introduction of multiple alloying elements. Alloys are available in a variety of forms—ingot, bar, buttons, flake and coiled and cut rod—each designed to increase throughput, uniformity and better predictability as com-

pared to pure elements or salts.

Every KB Alloys product is backed by outstanding worldwide technical support and a company-wide commitment to customer service. Experienced sales engineers, research metallurgists and trained agents can help you select the best product for your process and application. We can also provide responsive, knowledgeable answers and technical support to help you overcome problems and get the most out of the products you produce.

Strategic, customer-focused manufacturing and worldwide inventories. With advanced ISO 9002 certified manufacturing facilities in both the Eastern and Western United States, as well as in Great Britain, and strategically located customer-focused inventories, we provide fast, reliable delivery of consistently high-quality master alloys anywhere in the world.

KHD HUMBOLDT WEDAG AG

#923

Cologne, Germany

KHD Humboldt Wedag AG has its main fields of activities in the design and construction of plants for the base materials industries, such as cement production, minerals processing, coal preparation and aluminium smelting. For the aluminium industry, KHD Humboldt Wedag AG designs, supplies and installs

- bauxite crushing and grinding systems
- green anode plants
- anode handling systems
- rodding plants
- butts crushing plants
- pot line equipment

and is the world-leading supplier of vibrating compactors for forming of green anodes, cathode blocks and electrodes, with more than seventy units supplied to the aluminium and carbon products industries.

**KABERT INDUSTRIES, INC.**

#1016

Villa Park, Illinois

Since 1960, Kabert Industries, Inc. has been furnishing the aluminum industry with casting supplies. Fiberglass cloth, an inexpensive and effective method of nonferrous molten metal distribution and filtration, is specially woven for the aluminum industry at our plant in Lynn, Indiana. Plain, leno and twill weave cloth styles are woven to specification. Three, four or six strand yarn costs are available.

Also at our Lynn facility, the cloth is cut and sewn into a variety of mini channel bags, trough socks and many other shapes. Other products available include gaskets, vacuum formed shapes, and ceramic foam filters.

KAISER/CELTROL III

#1122
Mead, Washington

Proven Automated Process Control for Aluminum Reduction Cells

Kaiser Aluminum & Chemical Corporation has a 50-year history of technological innovation, and of providing aluminum reduction technology and related technical services to aluminum companies worldwide. Kaiser supplies automated process control systems for reduction cells in existing smelters with either prebake or Soderberg cell technology. This system, trademarked CELTROL, has been installed in 14 smelters worldwide and controls about 7000 reduction cells.

This system provides operating personnel with highly detailed information for immediate use at the reduction cell, and provides process personnel with a vast amount of historical data on each cell for trending and analysis purposes. Please visit the Kaiser booth and discover what CELTROL can do for you.

KEMPE INTERNATIONAL

932, 934
Geelong, VIC, Australia

Kempe International provides specialized equipment, complete turnkey facilities, engineering consulting, and maintenance support to the aluminum smelting industry.

Kempe design and manufacture an extensive range of proprietary equipment and have license agreements with Alcoa, Comalco and Capral for other equipment, technology and systems. The equipment we can provide includes:

- Paste Plant & Green Anode Storage
- Green Anode Cooling Systems
- Green Anode Conveying & Handling Equipment
- Baking Furnace & Baked Anode Storage
- Baked Anode Conveying & Handling Equipment
- Anode Block Cleaning Machines
- Stub Hole Cleaning Machines
- Rodding Shop
- Load/Unload Stations
- Pallet Tipping Stations
- Hot & Cold Butt Cleaning Machines
- Combination Stripping Presses
- Cast Iron Pouring Stations
- P&F Conveyor Systems
- Rod Straightening Presses
- Stub Analyzing Stations
- Stub Straightening Machines
- Stub Repair Facilities
- Materials Handling
- Hot Bath Cooling Systems

- Bath Processing Facilities
- Carbon Recycling Facilities
- Potrooms
- Crustbreakers & Feeders
- Anode Clamps
- Casthouse
- Crucible Cleaning Machines
- Tapping Pipe Cleaning Machines
- Bent Tapping Pipe Cleaning Machines
- Siphon Pipe Cleaning Machines



KEMPE
INTERNATIONAL

KLÖCKNER-MOELLER GmbH

#1131, 1133
Bonn, Germany

Klöckner-Moeller is the competent contact for power management and automation, with almost 7,000 committed employees, 23 production plants and 350 sales offices around the world.

Klöckner-Moeller develops, produces and markets LV switchgear and products, and power distribution. With our broad product range of over 35,000 individual types, we rank among the top suppliers in the electrical industry offering everything from transformers to a complete range of contactors, to circuit-breakers and the latest generation compact programmable control system. Also, our range of distribution equipment, including distribution boards and busbar trunking distribution systems, is the most comprehensive available in the European market to date. Thus, from individual components to complete plant systems, Klöckner-Moeller has the answer to virtually any customer requirement

KOVEX CORPORATION

#1034
Shoreview, Minnesota

Kovex Corporation is a manufacturer of high precision 3D surface inspection instruments based on cutting edge optical technologies. Our new product, the **KovexVision™** laser scanning confocal microscope is a low cost, high performance surface inspection and metrology instrument. Utilizing new proprietary scanning technology, high resolution 3D im-

ages are generated without contacting your sample. The 3D data can then be viewed, manipulated and measured from any angle or orientation. **KovexVision™** offers a unique combination of high resolution, a large field of view, long working distances and quantitative 3D capabilities. **KovexVision™** is the most precise surface measurement tool for all of your sub-micron applications.

L

LAKEFIELD RESEARCH LTD.

#1236
Lakefield, Ontario, Canada

LAROX

#1415 <http://www.larox.fi>
Columbia, Maryland

Larox, Inc. is an international manufacturer and distributor of a complete line of pressure filtration equipment and slurry valves. Larox pressure filters have a revolutionary vertical design that offers superior dewatering performance. Operation is fully automatic. Capacity is up to 150 tons of dry solids per hour. Cycle times are as short as 6 minutes. The filters contain no continuously moving parts. Maintenance is minimal, resulting in filter availability of up to 95%. Achieve up to 94% dry cake, clearer filtrate and reduce operating costs up to 70% compared to other dewatering systems. Optional washing to produce high purity cakes is also available.

LAROX



Larox PF Pressure Filter

LECO CORPORATION

#1038 <http://www.lecousa.com>
St Joseph, Michigan

LEM DYNAMP

#1101
Grove City, Ohio

The Metals Industries are particularly interested in High Current Measurement and Management Information Systems. These give the manager accurate reports of AC to DC Energy Conversion, Current efficiency and Production Energy efficiency. At the heart of these systems are 0.1% accurate, high current (4ka to 500ka) transducers.

Other instruments of interest are portable units for measuring anode or cathode currents and safety related models include rectifier protection systems and the RDCMS family of power supply current distribution monitors.

LEM is a global supplier of Current and Voltage Transducers, Instruments, Probes, Power Semiconductor Testers, as well as Power Network Analyzers.



LEM

LIGHT METAL AGE

#930 <http://www.lightmetalage.com>
San Francisco, California

For over 55 years, Light Metal Age magazine has covered primary production and semi-fabrication of light metals, primarily Aluminum and associated non-ferrous industries throughout the world. Circulation goes to smelters, rolling mills, extrusion plants, sheet rod and wire mills, foundries and die casting, anodizing, roll coating, coil coating and forging operations.

Recipients are executives, presidents, general managers, plant managers, technicians, metallurgists, chemists and engineers responsible for fabrication, production and operation.



LOI, INC.

#1329, 1331
Bethel Park, Pennsylvania

Schmitz + Apelt LOI is well known throughout the world as a major supplier to the aluminum industry with a wide product range.

Aluminum Melting and Casting:
Delivery of complete plants for melting/recycling of various Al materials and scraps, including flue gas purification, metal treatment, charging and casting equipment.

Design and manufacture of:
crucible furnaces
auto ladles for gravity and die-casting
hearth- and dry-hearth melting furnaces, stationary or tiltable
rotary drum-type melting furnaces
twin-chamber melting furnaces for the recycling of various scraps without salt
casting conveyor, air-/water-cooled
stacking equipment for ingots
also delivery of complete stacking, marking, weighing and strapping lines.

Heat Treatment

Heat treatment plants for structural aluminum parts (wheels, cylinder heads, axle guides, etc.) for the continuous and non-continuous operation, for the process steps below:

Solution annealing
Quenching
Artificial aging

Artificial aging plants for extruded aluminum sections or profiles, pressing-tool pre-heating plants, with automatic tool transport used in press shops for extruded profiles.

LOMA MACHINE MANUFACTURING, INC.

#641, 642
New Rochelle, New York

LONDON & SCANDINAVIAN METALLURGICAL CO LTD.

#632
London, England

M

MAERZ-GAUTSCHI LTD.

#921
Tagerwilten, Switzerland

MAERZ OFENBAU GmbH

#1032, 1034
Dusseldorf, Germany

MASTER ALLOYS COMPANY

#803
Munster, Indiana

Master Alloys will be exhibiting its popular 100% canned hardeners. The canned hardener is 100% element in a pre-weighed, moisture-proof aluminum can. The element is not released into the aluminum until it is under the melt which negates any oxidation and results in very high recoveries.

This unique way to alloy aluminum has many advantages over other forms of hardeners. Besides being pre-weighed and moisture proof as stated above, the product is easy to store; reduces inventory; easy to use; fast dissolution; high recoveries; free from contamination; and guaranteed composition.

In addition to the can hardeners, Master Alloys supplies grain refiners and specialty alloys to the aluminum industry.

*pick-up from page A9
from Nov 97JOM*

MAXON CORPORATION

#1031
Muncie, Illinois

Maxon Corporation has been a manufacturer of quality industrial combustion equipment and valves for over 80 years with headquarters in Muncie, Indiana. Worldwide representation includes a subsidiary in Brussels, Belgium, an Asian Pacific sales office in Singapore, and over 60 other sales locations.

After leading the glass industry for over 10 years, the Maxon OXY-THERM Burner is also being utilized in other high temperature applications, such as preheating, rotary melting, incineration, and forge furnaces.

OXY-THERM Burners provide accelerated heat transfer, produce increased infrared transmission and their non-lifting flames have higher luminosity and can increase production rates by more than 20%.

Other OXY-THERM advantages include a 5:1 turndown ratio, maintenance-free design, oxy-pilot for easy lighting and stability, multi-fuel capability and low emissions.



McALLISTER MILLS CO.

#721, 723
Independence, Virginia

Come visit us at the TMS Annual Meeting, February 15-19, 1998 in San Antonio!

We are anxious to show the newest applications, including the ones for the Aluminum Industry, that our Maxsil CF6-2000 Ceramic Free, Needled Blanket is being used. This product may be your solution for a 100% Shot-Free, Non-Respirable and Ceramic Free Environment.

As a manufacturer of High Temperature Textiles, we will also have on display our complete line of Fiberglass Fabrics, Coated Fiberglass Fabrics, Fiberglass Tapes, Fiberglass and Quartz Sewing Threads as well as our 2000 F Resistant Silica Fabric, Bulk Fiber, Molten Metal Filters and Needled Blanket.

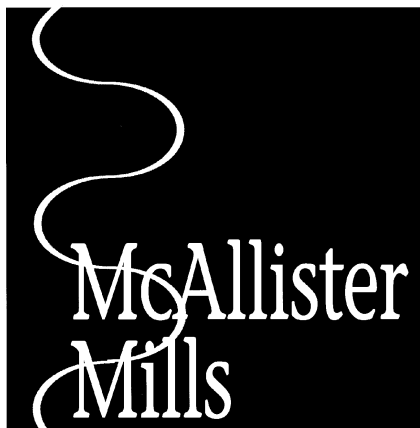

ENGINEERED INDUSTRIAL FABRICS

MECHATHERM INTERNATIONAL LTD.

#507
Kingswinford West Midlands, United Kingdom

Mechatherm is a privately owned company, formed in 1973, specializing in supplying furnaces and associated handling gear for aluminium melting, casting, extrusion and general heat treatment. Considerable success has also

been forthcoming in extrusion furnaces for pre-heating brass and copper billets.

Mechatherm have recently formed a technology agreement with another U.K. company Jesse Brough Metals which enables them now to offer complete plants for the recycling of aluminium drosses and contaminated aluminium scraps. Mechatherm are happy to consider tendering for turnkey new plants, upgrading existing plant or partial supply of equipment and are collaborating with Alu-Cut International Inc. (Stand #505) for the manufacture of equipment in the U.S.

The company operates a Quality System complying with BS-EN-ISO9001:1994 and has been approved by Lloyds Register Quality Assurance Limited.

Mechatherm will have available literature showing its product range and will be displaying photographs, posters and videos of installations.

MEDIA CYBERNETICS

#1310
Silver Spring, Maryland

Media Cybernetics designs and markets image processing software for end-users and software developers. Since 1981, Media Cybernetics has created products that offer ease of use, creative control and are compatible with a variety of hardware and software standards.

Image-Pro Plus provides image analysis solutions for Windows and Macintosh that are fast, accurate, and simple to use. Image-Pro provides analytical image processing capabilities. It includes a full range of counting, sizing, statistical and image enhancement tools. It has an intuitive and consistent interface designed to produce results quickly. Image-Pro is suitable for any research or industrial application where analysis of an image can help the user understand processes, make comparisons, or identify objects. Now available with Internet access.

Materials-Pro Analyzer is a specialized solution for the analysis of metals, ceramics, polymers, and other advanced materials. Materials-Pro provides materials science researchers with cost-effective software allowing users to automate the analysis of digitized images of specific materials products.

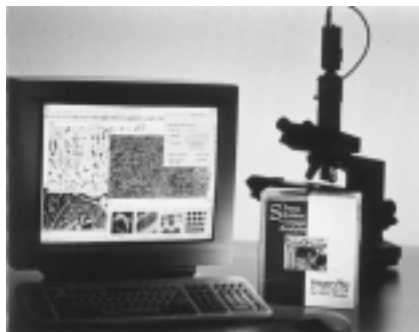

MEGAQUIP INDUSTRIES LTD.

#1103
Delta, British Columbia, Canada

METAL BULLETIN

#1106
New York, New York

For more than 80 years, Metal Bulletin has been reaching metals producers, semi-fabricators, traders, end users, recyclers and capital equipment suppliers in more than 100 countries. Metal Bulletin and its sister publication, Metal Bulletin Monthly, are more widely known and respected in the international metals markets than any other metals publications. In addition to MB and MBM, Metal Bulletin plc. Publishes numerous directories, and databooks for every segment of the ferrous and nonferrous metals industries. Metal Bulletin also arranges metals conferences throughout the world and provides an on-line metals information service (Metalnet).

METALLURGICAL SOCIETY OF CIM

#903
Montreal, Quebec, Canada

METALLICS SYSTEMS

#612
Solon, Ohio

Metallics Systems is a leading supplier of equipment for handling and processing non-ferrous molten metals. Metallics manufactures a complete line of molten metal pumps for circulating and degassing aluminum in reverberatory furnaces and transfer pumps for controlled, safe metal transfer. Metallics' state-of-the-art L-Series pumps will be displayed during the 1998 Exhibition. Metallics will also display its revolutionary Low Turbulence Scrap Submergence (LOTUSS) melting system. Featured will be Metallics' new Trough Tube Filter (TTF)TM which offers a unique combination of filtration efficiency, low capital and operating costs, ease of installation, and operator friendliness

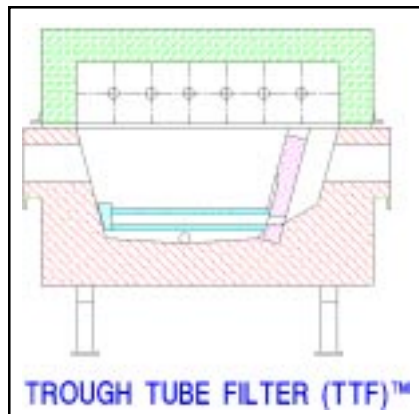

MILWARD ALLOYS, INC.

#1127
Lockport, New York

Milward Alloys, Inc. founded in 1948, is a manufacturer and worldwide supplier of aluminum based and copper based master alloys. Milward Alloys has aligned with KBM Affiliates

of The Netherlands to offer the aluminum industry the most complete master alloy line available in North America, combined with world class manufacturing and the finest in laboratory expertise and technical support.

Materials produced include a wide variety of grain refiners, modifiers, hardeners and degasifiers which are manufactured as 3/8" rod, conti-cast, ACU-STIX, and shot. All are designed for clean, easy, and precise additions for your convenience.

Plan to visit our booth to take advantage of our technical support, see our unique product line and discuss your product needs. Call us anytime at 716/434-5536 or fax to 716/434-3257.

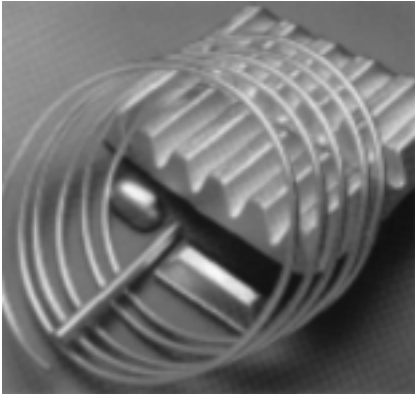

MODERN METALS MAGAZINE

#1006
Chicago, Illinois

MOLTECH

#1300
Carouge, Geneva, Switzerland

MOLTECH Products for Aluminum Cells

In over twenty years of research, the MOLTECH Group has developed products and processes for aluminum electrowinning, including TINOR Aluminum-wettable Protective Cathode Coating, OPANOR Anode Oxidation Protection and EXCELNOR Side Wall Oxidation Protection, which have been tested extensively in laboratories and commercial Cells and are now available for commercial use.

The ultimate goal of MOLTECH research is the development of the NOVANOR non-carbon non-consumable anode to replace carbon anodes, thereby improving Cell performance, reducing pollution in their fabrication and use, and in residue disposal.

NOVANOR anode laboratory test results are very promising and pilot scale tests are now in process. MOLTECH invites everyone to visit its stand at TMS, which will feature innovative MOLTECH products including NOVANOR.

MOLTEN METAL EQUIPMENT INNOVATIONS, INC.

#704
Middlefield, Ohio

Molten Metal Equipment Innovations, Inc is a dynamic and innovative company that de-

signs and manufactures people-friendly equipment for the aluminum industry. Products include molten metal circulation, transfer and gas injection pumps, scrap melting systems and rotary degassers. We specialize in the ability to customize any of our products to meet our customers' unique needs. MMEI invests heavily into engineering, new products and upgrading of our existing equipment. We are fully staffed to offer a variety of services to our customers. This includes on-site installation and start-up of the initial equipment as well as continued field support



MTO Steinhoff, Wilhelm Nachf. GmbH

#1422
Duisburg, Germany

CAST HOUSE SOLUTIONS FOR QUALITY PRODUCTS AT LOWEST COST

Horizontal Casting

Tomorrow's technology for casting of copper and copper alloys into billets, slabs, strips, rods and hollows; MTO-Steinhoff has the experience to provide total solutions for your casting program. MTO-Steinhoff horizontal casting machines and mold design are based on decades of casting experience within our engineering staff.

Vertical Continuous Casting

While recognizing the recent trend toward horizontal casting, there is still a significant role for the vertical casting unit, MTO-Steinhoff's vertical semi-continuous slab and billet casters not only have the flexibility to offer fast alloy changes and fast format changes, but also provide unequalled yield in terms of size and cross section.

We invite you to request our advice on any cast house expansion or redesign.

Wilh. Steinhoff Nachf. GmbH
Arnold-Dehnen-Strasse 49
47138 Duisburg
Germany

Tel: 0049-203-9945-0
Fax: 0049-203-9945-129
E-Mail: MTOSTEINHOFF@compuserve.com
Internet: www.mtosteinhoff.com

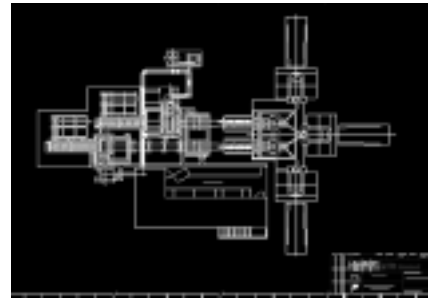

MURLIN CHEMICAL INC.

#1222
West Conshohocken, Pennsylvania

Murlin Chemical, Inc. manufactures Bone Ash at its plant located in West Conshohocken, Pennsylvania, USA. Established in 1978, Murlin Chemical supplies Bone Ash to the non-ferrous metals industry worldwide.

Bone Ash is accepted by the non-ferrous metals industry as a superior release agent. Application of Bone Ash to a surface exposed to molten metal provides a consistent barrier against attack by the molten metal.

Plan to visit us at Booth 1222 at the 1998 TMS Exhibition to learn about the advantages of Bone Ash and some exciting new things we are doing with Bone Ash. You may contact us at (610) 825-1165 or fax us at (610) 825-8659 for further information.

N

NKM

#1309, 1311
Rotterdam, Holland

NKM and the Aluminium Industry

NKM products have found their way around the world since 1933. Ore transport installations exported to Beire, floating cranes to India and Turkey, custom designed loading- and transport installations to New Zealand, India, Hong Kong and Portugal, salt reclaimers to the United States, concrete loaders to Venezuela and since 1963 specially designed cranes and machines for aluminium reduction plants. Hundreds of these cranes and machines have now been installed worldwide.

Over the years, NKM has constantly upgraded and improved its equipment for the aluminium industry. Besides crane transfer systems NKM supplies the aluminium industry with cathode cranes, baking furnace cranes, pot tending cranes, jacking frames, anode stacking cranes, crucible cleaning machines, pipe

cleaning machines, pre-heaters and refractory heaters, billet handling cranes and casthouse cranes. See us at booth 1309, Mr. Frits Felkers and Mr. Cees Langeveld. Or phone or fax NKM in Holland: tel. +31 10 4873462 fax +31 10 4873478

N.V. GOUDA VUURVAST

#905
Gouda, Netherlands

N.V. Gouda Vuurvast manufactures, supplies and installs high quality refractory materials for close to one century. With production facilities in the Netherlands, N.V. Gouda Vuurvast does supply all major industries throughout the world. The integrated approach of refractory-research, engineering, production and installation (supervision) is unique and enables N.V. Gouda Vuurvast to guarantee high performance refractory applications. Worldwide supply, flexibility, and long-standing experience make N.V. Gouda Vuurvast your reliable partner for all refractory applications.

In the aluminium industry, N.V. Gouda Vuurvast is world-famous for its AK 46 S refractory brick used in Carbon Bake Furnaces of all major designs and its AK 85 range of refractory bricks suitable for all types and designs of holding and melting furnaces.

NALCO CHEMICAL CO.

#622, 624
Naperville, Illinois

NATIONAL REFRACTORIES & MINERALS CORP.

#828, 830
Columbiana, Ohio

The National Refractories exhibit will highlight applications of EZ³ and FUSiO₂N. EZ³ products expand the uses of the company's well known EZ Cast product line. FUSiO₂N products are National's new line of fused silica preformed shapes, foam blocks, castables, and cement.

EZ³ castables are a family of products designed to offer three options for installation; pouring, gunning, and pumping. The unique materials can be installed by mixing and pouring into place without vibration. They can be mixed and pumped some distance to a form. Best of all, they can now be gunned with standard swing-valve pumping equipment.

FUSiO₂N preformed shapes are pure fused silica. A unique production process allows National to be very cost competitive while offering customized materials and shapes to meet customers needs.

NECO INC.

#937
Salisbury, North Carolina

THE NONFERROUS METALS SOCIETY OF CHINA

#1205
Beijing, China

NORTH AMERICAN MANUFACTURING

#1000, 1001
Cleveland, Ohio

NORTH AMERICAN REFRACTORIES COMPANY

#1028, 1030
Mifflinburg, Pennsylvania

P

PARKER-HANNIFIN

#1436, 1438
Des Plaines, Illinois

PECHINEY GROUP

#714, 716
Mamaroneck, NY

With an annual alumina production of nearly 2 Mt. and aluminium production of 1 Mt., Pechiney is one of the major producers.

The Aluminium Pechiney Technology has always been very innovative and has set many records, particularly for power consumption, cathode performances and environmental protection (more than 2800 AP 18 cells and 2,000 AP-30 cells are operated around the world).

Pechiney Aluminium Engineering markets the Pechiney Group's Technologies for casthouse equipment. They are specialists in the areas of degassing and filtration, including its recently improved Alpur TS system, automatic DC casters and continuous strip casters using the Jumbo 3C process. They are also suppliers of technical assistance in the manufacture of flat-rolled aluminium products, for rolling and finishing or basic engineering, and operating know-how for turn key plants.

PECHINEY

PERMATECH, INC.

#532
Graham, North Carolina

Permatech designs, engineers and manufactures precision precast refractory parts and assemblies for the molten aluminum industry. The major focus of our business is directed toward metal transportation, filtration and casting. We specialize in precision, tight tolerance parts that can be adapted to improve any casting system. Major product categories include: transition plates, thimbles, ceramic foam filter bowls, large metal treatment boxes, troughs and specialty materials. Permatech products include unique castables and superior insulating products such as Non-Wetting Moldable and Foam Insulation. New product develop-

ment will be the major focus of our display at this year's TMS Show. Our highlighted products and services will be as follows:

- Low density LD 75 transition plates, no in service shrinkage
- Large precast boxes and degassing systems assemblies
- Application specific, innovative castable product
- Drache Cerapor ceramic foam filters
- Delta insulating parts, casting table tops and troughing
- Molten Metal Systems Assemblies; including filter bowls, troughing and large box units
- Specific precast ceramic parts, unique designs for specific customers

Permatech has established key strategic alliances with international representatives so that we can service the needs of our customers around the world.

Our goal is to provide innovative products and services that solve our customers problems, improve metal quality, reduce total operating costs and improve production efficiency.

Visit with us and discuss your application at Booth 532
ISO 9001 Registered

PERMATECH

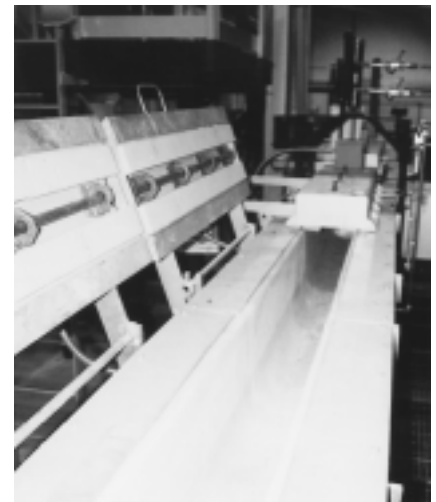

CARL AUG PICARD GMBH & CO. KG

#931
Remscheid, Germany

Picard is an international company with subsidiaries in Germany, England, USA and Hong Kong.

For more than 120 years, Picard is well known as manufacturer of Wear Parts for various industries. One of the main production ranges of the company is the production of Wear Parts for Anode-paste-mixers like Liners/wearing Plates, Kneading Teeth, and Screws Flights / Paddle Screws. These Wear Parts can be offered in two executions:

- a) Standard - Execution
 - b) Special High-wear-resistant Execution
- The Standard Execution is a hard-faced ex-

ecution to achieve good and long service-time.

The High-wear-resistant Execution guarantees an extraordinary long time and wear-resistance which is caused by hardfacing and coating a tungsten-carbide material.

Besides the new parts, C.A. Picard offers an economical and favorable re-conditioning service which either can be arranged in your plant or our works.

Are you interested? Please take the chance to ask our specialists during the TMS Show or contact us directly: C.A. Picard GmbH & Co. KG

Hasteraue 9, D-42857 Remscheid
P.O. Box 140440, D 42825 Remscheid
Phone ++49/2191/893-136
Fax ++49/2191/893/223

PLIBRICO

#904
Chicago, Illinois

Plibrico Company is a manufacturer and installer of monolithic refractories. Plibrico's product line is composed of a wide range of plastics, castables, and maintenance materials suitable for just about any refractory application. Not only can Plibrico offer a variety of materials, we can install these materials utilizing various methods, such as our patented HyRate and Mini-HyRate plastic gunning, pumping, Plishot, gunning, etc. Please stop by our booth and discuss how the Plibrico representative in your area can successfully solve your refractory applications.



PREMELT SYSTEMS

#1235, 1237
Kalamazoo, Michigan

PREMELT is the foremost supplier of total metal scrap cleaning and processing systems worldwide. PREMELT'S patented, innovative metal processing equipment and techniques result in unprecedented operational efficiencies and cost reductions. Annual metal cost savings of 10% or more are common in most PREMELT Systems. Engineering and supplying light metal scrap processing, cleaning, drying and furnace charging systems for the metals industry since 1981.

PREMIER REFRACTORIES AND CHEMICALS, INC.

#1008, 1010
Clayton, Missouri

Premier Refractories, a leader in Monolithic Refractories for the Aluminum Industry, offers a complete line of products including Castables, Plastics, Mortars and Ceramic Fibers

Featured Products:

Alugard - Non Wetting Refractories for Aluminum Contact

BluRam Plastic - The Original Mullite Based Plastic

Monomax - A Monolithic Ceramic Fiber Product

TruForm - Custom Engineered Refractory Shapes



PRINCETON GAMMA TECH., INC.

#1327 <http://www.pgt.com>
Princeton, New Jersey

PROCEDAIR INDUSTRIES

#901
Montreal, Quebec, Canada

PRYOR GIGGEY CO.

#737
Chehalis, Washington

Pryor Giggey celebrates its 50th anniversary in 1998. We have been providing refractory products to the industry with unparalleled customer service and refractory innovation throughout our history. We have a long customer list of satisfied customers in the aluminum and copper producing industries and continue to strive for better performance and lower refractory cost to the customer. We are the exclusive licensee of Lafarge Refractaire Monolithiques for North America, which provides us with the state of the art in monolithic technology for solving customer demands in problem applications and severe service conditions. We are the first producer to offer true self flow technology and to provide successful veneer repairs. When you have a problem application and want the first team to help solve your refractory needs, give us a call at 1-800-4-hotrox (800-446-8769) or stop by our booth at the TMS exhibition, #737



PYROTEK, INC.

#506
Spokane, Washington

Pyrotek offers aluminium producers a complete range of materials for applications in carbon bake, pot rooms, and casting areas. At TMS in San Antonio, Texas, February 1998, Pyrotek will exhibit high-tech ceramics, casting tips for strip casters, and many other products special for aluminium operations. Of particular interest will be an exhibit of the latest Alpur degassing equipment with fully sealed reaction chambers to reduce oxidation and increase the life of graphite parts.

For more information contact Sue Daniels at Pyrotek, E 9503 Montgomery Ave, Spokane, WA 99206, USA. Phone: 509-926-6212 or Fax: 509-927-2408.

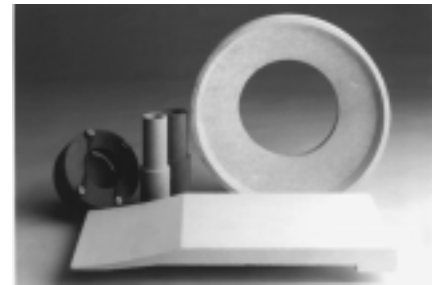

Floats, pins, transition ring and caster tip section.

R&D CARBON LTD

#922
Zurich, Switzerland

R&D Carbon Ltd. serves the petroleum coke, pitch and aluminum industries:

Research and Development: Basic research is carried out to better understand relationships between raw material properties and process parameters.

Technical Services: Raw material evaluations for anodes, cathodes, and other carbon products are performed in bench or pilot plant scale. Technology audits and in-plant process optimisation are carried out at customer's plants.

Laboratory Test Equipment: Easily operated and reliable test instruments have set worldwide standards for testing carbon products.

Bake Furnace Process Control: An integrated bake furnace firing and process control system guarantees high productivity, low energy consumption and consistent anode quality.

Training: Special training courses in the basics of anode manufacture are offered in our training centre or at customer's location.

Engineering: A new process for green anode manufacturing allows the reduction in investment and operating cost. In cooperation

with leading engineering companies our patented anode technology is marketed worldwide.

RESEARCH - COTTRELL

#736, 738

Branchburg, New Jersey

Research-Cottrell is the exclusive worldwide licensee for Alcoa's A-398 and A-446 fluidized bed dry scrubbing technologies. The technologies—the basis for the new MACT rules—provide state-of-the-art emission control and fluoride recovery from both primary aluminum potline and bake oven applications. A-398 systems are currently installed on more than 20 smelters (56 potlines) worldwide, treating over 20 million cfm of potroom gases from both prebake and Soderburg-type reduction cells. The A-398 and A-446 technologies routinely achieve greater than 99.9% fluoride removal efficiencies. In addition to controlling fluorides and particulate, the A-446 scrubbing process significantly reduces hydrocarbons (Tars, POM, B(a)P) and SO₂ emissions from bakeoven furnaces, without a separate spray cooling chamber. Alcoa's proven fluid bed scrubber systems and Research-Cottrell's vast air pollution control experience in fabric filter, electrostatic precipitator, wet and dry scrubber, and VOC-removal technologies, combine to allow Research-Cottrell to offer the "Best" technologies at a competitive price.



REX ROTO CORPORATION

#731, 733

Fowlerville, Michigan

Here is an opportunity you won't get very often. A place to go for help that has forty years of experience. The largest company of its kind in the country. A staff of experienced and knowledgeable people, two plant locations plus corporate offices with research and development capabilities. All of this designed and dedicated to helping you solve your problems, the problems of heat containment, specialty refractories and superior results in performance. Our recommendations are based on experience and experimentation and not just guess work. Our programs provide extensive engineering and design services and if we haven't done it before we will find a way to do it this time.

Have a good day by making Rex Roto Corporation your refractory division and the problem solvers for your refractory needs.

*pick-up from page A12
Nov 97 JOM*

RIGAKU/USA, INC.

#1041

Danvers, Massachusetts

Rigaku was founded in 1923 and has been at the forefront of analytical and industrial X-ray technology ever since. With its long established reputation for proven technology and innovation, Rigaku has produced the most comprehensive line of X-ray diffraction and fluorescence instrumentation available.

Complete elemental and structural analysis can be performed with X-rays. This technique offers a small footprint, minimal sample prep, accurate analysis, rapid turnaround, and, it's non-destructive.

WDXRF rivals the accuracy of wet chemical techniques in a fraction of the time; it can analyze elements over six orders of magnitude, from ppm's to 100%. Rigaku's Simultaneous WDXRF system allows for up to 40 elements to be measured at one time. It can also be configured with light (F-Ti) and heavy (Ti-U) element scanning channels for added versatility.

Rigaku's Miniflex allows for diffraction pattern "fingerprinting". Rigaku's XRD systems can identify and quantify crystalline compounds and structures.

Rigaku and its X-ray systems put X-rays to work the world over.

S

SAINT GOBAIN INDUSTRIAL CERAMICS NORTON PRIMARY METALS SYSTEMS

#1021, 1023

Worcester, Massachusetts

Norton provides refractories for many primary metal containment and/or critical contact applications.

Norton refractory products for the aluminum industry include reduction cell sidewall bricks and blocks, reverberatory furnace ramp & floor bricks, other high-erosion components, mortars, ramming cements, dry vibration cements and low-moisture castables. Norton also supplies refractories for critical areas in filter systems, molten metal pumps, troughs and heat exchangers.

Norton refractory products for the copper industry include shaft furnace liners, bricks, burner components, associated mortars and ramming cements, low moisture-high strength castables for launders, spoons and other critical metal contact applications.

The major strengths of material expertise, forming techniques, application experience, and statistical process control result in high quality bonded and monolithic silicon carbide, alumina, and mullite refractory products for a wide variety of applications.

SCHARF WESTFALIA INDUSTRIAL SYSTEMS

#1215

Lünen, Germany

Scharf Westfalia designs, develops, manufactures, and supplies turn key plants and systems as well as components for the Aluminium Industry.

The Aluminium division is responsible, amongst others, for state-of-the-art turn key Anode Rodding Shops, Anode Handling and Storage, as well as Butt and Bath Treatment Plants for the Aluminium Industry.

The knowledge our experts have at their fingertips is reflected by their handling of international projects.

As an international, dynamic mechanical engineering company, Scharf Westfalia offers professional know how and a progressive technology for the solution of challenging problems.

Our activities cover the following disciplines:

- Planning
- Design
- Engineering
- Manufacture
- Logistic
- Training
- Assembly
- Commissioning
- Maintenance
- Project Management

The following systems are presenting our main product line:

Turn key plants for:

- Anode Rodding Shops
- Cleaning and handling of bath and butt material
- Baked and green anode handling and storage systems
- Cooling tunnel for anode butts and bath material
- Crucible cleaning
- Fully automated transport System for green and baked anodes
- Anode traverse beam for the handling of anodes in the electrolyte cell

SECO/WARWICK

#1335, 1337

Meadville, Pennsylvania

SECO/WARWICK produces Custom Engineered Heat Processing Furnaces and Systems for heat processing non-ferrous metals.

We want to be your single source for furnace systems, beginning with initial support services, continuing through manufacturing, installation, furnace start-up and personnel training. Focused Project Teams concentrate on specific specialty areas:

- Aluminum Braze Team - Controlled atmosphere brazing using a non-corrosive flux process for appliances and automotive heat exchangers: radiators, condensers, oil coolers, evaporators, heaters and charge air coolers.
- Aluminum Process Team - Heat treat furnaces for annealing, homogenizing, preheating and aging of aluminum.
- Molten Metal Team - Melting furnaces for non-ferrous metals including melting sows, solids and scrap, cleaning molten metal before casting, die casting, aluminum recycling and magnesium recycling.
- Solution Heat Treat Team - Aluminum solution heat treating furnaces for castings, forgings, extrusions, aeronautical applications and billet preheating.

SECO/WARWICK is ISO 9001 Certified for Quality.



SELCOM, INC.

1136, 1138
Southfield, Michigan

The LaserPour® Aluminum Level Control Systems from Selcom are high-speed, closed-loop control systems which automatically and precisely regulate the level of molten metal in a mold, headbox or tundish during the entire casting process. Using real-time laser level measurement, the systems control the metal level from start-up through the filling stage to finished casting. Metal flow from the furnace can also be controlled to assure a fast and consistent fill rate to the desired level within a very high degree of accuracy.

While Selcom's products for aluminum level control are designed to provide automatic, easy-to-use, reliable and virtually maintenance-free solutions, the final measurement of success is always based on how it benefits the customers. In this regard, our experience has been entirely positive.

Selcom
LASER MEASUREMENTS

SELEE CORPORATION

#626
Hendersonville, NC

SELEE Corporation is the premier manufacturer of ceramic foam filters for use in the ferrous and non-ferrous metals industries as well as innovative refractory and preheat systems and a growing line of specialty products.

A18

SELEE Corporation is THE ONLY CERAMIC FOAM FILTER AND REFRACTORIES SUPPLIER IN THE WORLD TO ACHIEVE ISO 9001 AND FORD Q1 QUALITY CERTIFICATIONS. This means SELEE Corporation will deliver to you on time the best quality products to the industry.

SELEE has maintained the market and technical leadership for the ceramic foam industry by developing strong partnerships with customers. These partnerships allow customers to share SELEE resources to solve all types of problems.

SELEE resources include:

- Full Range of Ceramic Foam Filters
- Custom Refractories, Bowls, Burners
- Specialty Consumables
- Fully Equipped Metallurgical Lab
- A Team of Applications Engineers
- A Dedicated Customer Service Department
- Nationwide Direct Sales Force
- R&D Pilot Plant Facility for Partnership Developments
- TQM Programs that Provide:
 - Continuous Improvement
 - Full Product Certification
 - Self-Directed Work Teams
 - On-Site Customer Training Programs



SENTECH CORPORATION

#1022 (4 sp)
Tempe, Arizona

SERMAS AS

#700
Saint Quentin Sur Isere, France

SETARAM

#642
Caluire, France

SHIELDALLOY METALLURGICAL CORP.

#634
Newfield, New Jersey

Shieldalloy Metallurgical Corporation (SMC) Aluminum Products Group has been producing grain refiners, master alloys, and compacted products for over 25 years.

SMC was the first company to develop and market the newest technology of Continuous Cast and Conformed rod. This technology results in the highest quality grain refining rod, strontium-aluminum rod, and master alloy rod in the industry.

Our continuing efforts in technical development have resulted in a variety of new grain refiners, master alloys, and hardeners for use in the Primary, Secondary, and Foundry markets. Our newest grain refiners, 3% Ti 0.15% C rod, may offer benefits to your particular operation. In addition we produce CastCut, a product which offers very tight weight control for precision addition requirements. SMC also

produces hardeners of Chrome, Iron, Copper and Manganese in briquettes as well as our newest form, ALTAB.

Shieldalloy Metallurgical remains the only domestic producer to offer a broad range of grain refiners, master alloys, modifiers, and hardeners. We invite you to visit our booth to discuss these new alloys and other new products that we have developed.

SHIVA TECHNOLOGIES, INC.

#1424
Cicero, New York

Shiva Technologies is an independent commercial laboratory which specializes in the analysis of metals and alloys for their elemental constituents. Analysis of major, minor, trace, and ultratrace elements is available. Analytical techniques used include Glow Discharge Mass Spectrometry, Glow Discharge Atomic Absorption, Leco, Wet Chemical Determinations, Inductively Coupled Plasma / Mass Spectrometry, Flame Atomic Absorption, and others. Shiva maintains analytical facilities in New York, California, France, and India. All our facilities specialize in offering high quality services with rapid turnaround. Services from India include extensive Wet Chemical techniques and are extremely cost effective. Our New York, California, and France laboratories are all ISO 9002 Registered, and India is currently in preparation to be audited to the same criteria.

SILVER NEEDLE, INC.

#1210, 1212
Kellogg, Idaho

WE KNOW WHO SIGNS OUR PAYCHECKS
OUR CUSTOMERS
WE WANT TO WORK FOR YOU

Our company started in a foundry: 12 years working and producing safe yet comfortable clothing. We listen because we know the frustrations of not being understood, of wearing clothing that doesn't fit, rubs, scratches and confines. Give us the opportunity to work for you and see if Silver Needle can make a difference.

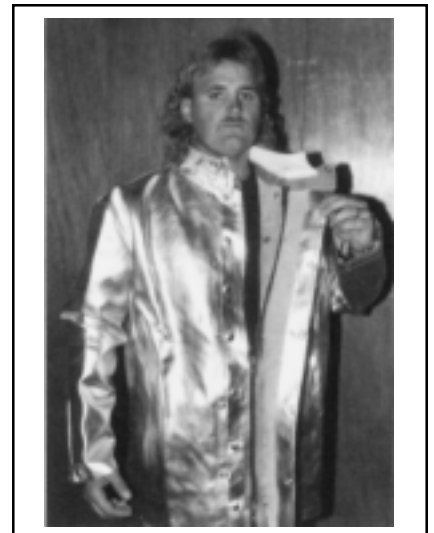

**SKAMOL -
High Temperature Insulation**

#1105, 1107
Nykobing Mors, DENMARK

Skamol is one of the world's leading manufacturers and suppliers of thermal insulation to the aluminium industry. We offer a wide range of thermal insulating products for service temperature up to 1150°C (2102°F). The Skamol product range includes Moler insulating bricks, Perlite insulating bricks and blocks, Calcium Silicate block insulation, insulating bricks and slabs based on Vermiculite, special shapes, insulating mortars, castables and aggregates.

Recently, we have joined forces with Norwegian Elkem Carbon in marketing two new types of cold ramming pastes based on Electrically Calcined Anthracite (ECA). The development of these cold ramming pastes is an important improvement of the conventional lining concept, reducing emissions of hazardous tar and PAH (polyaromatic hydrocarbons) to a minimum and increasing pot life and profitability.

We look forward to seeing you at our booth. For further information contact one of our offices:

Skamol a/s, Denmark, tel.: +45 9772 1533, fax: +45 9772 4975

Skamol UK, tel.: +44 (1206) 302 330, fax: +44 (1206) 304 576

Skamol, Inc., N.Y., USA, tel.: +1 (716) 831 8682, fax: +1 (716) 831 8687

Technotherm GmbH, Germany, tel.: +49 2131 10 640, fax: +49 2131 106464



**skamol
insulation**

**LA SOCIÉTÉ DES TECHNOLOGIES
DE L'ALUMINIUM S.T.A.S. LTD**

#1113, 1115
Chicoutimi, Quebec, Canada

STAS, incorporated in 1989, is a young, dynamic and entrepreneurial company of approximately 100 employees specialising in the commercialisation of new technologically advanced equipment originating in R & D laboratories. Industry sectors include aluminium and mines serving a global market place.

STAS is a recognised leader in its innovative abilities to develop and fabricate sophisticated equipment to improve quality, reduce pollution and lower costs, using the latest in programmable automation systems. Examples

include dross coolers, filters, degassing equipment, rotary injectors, crucible cleaning machines, automatic guidance systems, etc.

STAS holds licences from Alcan, Noranda and others.

STAS is located in the heart of Québec, Canada, where more than 2,000,000 tonnes of aluminium alloys are produced in the most technologically advanced plants in the world. World-class R & D facilities located in Québec provide a continuing flow of new equipment to be commercialized; they include the Alcan R & D Centre, the Noranda Technological Centre, the Centre de recherche industrielle Québec, the National Research Centre.



**SOCIÉTÉ des TECHNOLOGIES
APPLIQUÉES du SAGUENAY**



SOUTHWEST RESEARCH INSTITUTE

#1214
San Antonio, Texas

Southwest Research Institute is a nonprofit applied R&D center that provides consultation services, field investigation, and in-depth laboratory studies for both government and industrial clients. SwRI has 13 operating divisions which include capabilities in materials sciences, structural and mechanical systems, engineering mechanics, and ballistics. Materials science research and development programs include materials development, processing, mechanical and physical property determinations, and service applications and performance.

SPECTORE CORP

#1137
Deefield Beach, Florida

Spectore Corp. is the developer and world leader of art titanium. The Company was conceived over 20 years ago in the United Kingdom by its founders. World headquarters and production facilities were established in Florida in 1983.

Spectore is singularly focused on developing the aesthetic properties unique to refractory metals. Its products are sold worldwide and range from jewelry and accessories to a broad scope of giftware and objects of art. Clients

range from jewelry galleries to television shopping, catalogs, theme parks, department and museum stores.

Our success has significantly elevated consumer awareness and perception of titanium in the global marketplace.

STEIN ATKINSON STORDY LTD.

#601
West Midlands, England

FURNACES FOR THE NEXT MILLENNIUM

With a wealth of knowledge and experience gained through over 80 years of solving customer's thermal and metallurgical process requirements around the world, Stein Atkinson Stordy Ltd are able to offer tailor made solutions to suit customer's individual process problems. Our partnership with american furnace company Gillespie & Powers enables us to serve the american market flawlessly.

Our product range includes:

Melting & Holding Furnaces: Static, Tilting, Side Well.

High speed Coil/Foil Annealers: Mass or jet flow, with or without charge machine.

Recycling: IDEX decoating system for recycling contaminated scrap in an environmentally friendly and cost effective manor.

Systems: Our in-house systems division can design, build and install custom made hardware/software to control or optimize your process.

Visit us at stand 600/601 to find out how we can help you.



STELLAR MATERIALS, INC.

#1203
Northville, Michigan

Thermbond is a unique new refractory material with features and benefits unavailable in traditional refractories. Thermbond is completely and naturally non-wetting to aluminum—with no additives to burn out. Thermbond bonds permanently to other refractories. Existing linings may be veneered and repaired with Thermbond.

SUPERIOR GRAPHITE CO.

#843
Chicago, Illinois

Superior Graphite Co has desinged a line of graphite lubricants and coatings specifically to meet the challenges of aluminum processing. All of our products are made with the finest ingredients and backed by our experienced

technical support staff. So, whether it be smelting, casting or extrusion or forging, Superior Graphite Co. can supply you with a premium graphite product to meet your processing requirements. Stop by booth #843 for more information.

T

TECHMO CAR & ENGINEERING

#927, 928, 1027

Limena, Padova, Italy

Since its foundation in 1961, Techmo Car's objective has always been to improve work conditions in the aluminium industry. Techmo Car was one of the first companies to study and introduce high-technology equipment and machinery into aluminium plants, with the double aim of a higher productivity and better, safer work conditions.

Production Range:

- Anode Changers: Standard and Multipurpose changing trucks, Pot-tending module.
- Breakers: Hammer and Wheel crust breakers, Spent pot lining breaker truck, Dustop long life hydraulic hammer.
- Casthouse: Scraps loader truck, Molten metal tapping truck, Molten metal ladle transporter, Furnace skimming and cleaning vehicle.
- Cleaners: Anode cavity cleaner, Baked anode cleaning station, Ladle cleaning station, Butt cleaning station, Vacuum Cleaner.
- Feeders: Alumina, Aluminium fluoride and crushed bath feeding trucks, Soederberg paste feeding truck, Anode covering truck, Point feeders.
- Miscellaneous: Full mechanization of stud pulling/resetting, Spading truck, Anode transporter truck, Anode lifting beam, Soederberg anode point cutter.



TECHNOLOGIES RESEARCH CORPORATION

#1304, 1306

Ann Arbor, Michigan

Technologies Research Corporation (TRC) is a subsidiary of the National Center for Manufacturing Sciences. TRC supplies high-quality professional services-services that are designed to complement, augment and leverage the technology resources of companies engaged in collaborative research and development.

TRC performs work for hire, offering a full

A20

complement of professional project management services that range from identifying project opportunities and funding sources, to forming and administering projects, to providing project reporting and closeout. In support of project efforts, TRC can tap into its parent company-the largest cross-industry consortium in the United States- for the necessary administrative, legal, accounting, purchasing and contracting capabilities.

The Aluminum Metal Matrix Composites Consortium (AIMMC) is an example of a typical project that TRC has supported with financial, contractual and project management expertise. This consortium is having its kick-off at the TMS show. Interested parties can stop by the TRC booth for more details.

TEXSEM LABORATORIES

#741

Provo, Utah

THERMAL CERAMICS & THERMIC REFRACTORIES

#812 (6 sp)

Augusta, Georgia



Thermal Ceramics manufactures a complete line of refractory bulk fibers, each offering its own unique combination of properties.

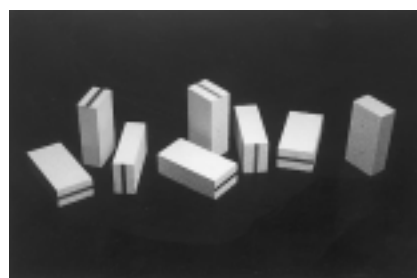

Lightweight Thermal Ceramics Insulating Firebrick

THERMAL SYSTEMS AMERICA

#1242

Canastota, New York

Thermal Systems America looks forward to the 1998 TMS Annual Meeting Exhibition. New this year is an interactive introduction to the engineering solutions and products available from Thermal Systems America.

Join us at our booth #1242 and:

1. Take a plant tour

2. Learn about the history of TSA

3. TSA Products include

- Floor Tile
- Crucibles
- Troughs
- Furnace components
- Filter Boxes
- Electrical Pass Throughs
- Starwheels
- Degassing Systems
- Flow Control

Most importantly, stop by and meet the people of TSA, who continue to make TSA the leader in providing engineering solutions to the industries we serve.

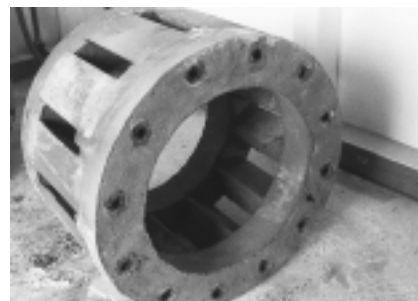

THERMCON OVENS BV

#1104

Geldermalsen, The Netherlands

Melting and holding furnaces for aluminium designed and built by Thermcon are in wide spread use with major aluminium producers around the world. In recent years D.C. casting machines and homogenizing furnaces have been added to the delivery program making Thermcon an all-round supplier for turn key casthouse packages. Recycling of aluminium scrap has been a priority with Thermcon for many years already, hence the development of side well furnaces with integrated incinerators, enclosed charging systems and delacquering and preheating installations in operation with clients such as V.A.W., Daiki in Japan.

Thermcon will give an update on the latest furnace technology available and developments underway to meet the requirements of the future, both with respect to improved economics and compliance with environmental regulations.

THERMPROCESS 99/DUSSELDORF TRADE SHOWS, INC.

#1209
Chicago, Illinois

Dusseldorf Trade Shows, Inc. will be presenting information on THERMPROCESS 99, International Exhibition for Industrial Furnaces and Thermic Production Processes. THERMPROCESS 99 is scheduled to be held June 9-15, 1999 at the Fairgrounds in Düsseldorf, Germany.

Exhibits at THERMPROCESS will showcase the following products: industrial furnaces, heat treatment plants and thermal processes; components and equipment for industrial furnaces; metallic engineering materials; and services related to the industrial furnace industry.

THERMPROCESS will be held in conjunction with four other related shows: GEOSPECTRA, International Trade Fair for Geotechnology and Applied Earth Sciences; GIFA, International Foundry Trade Fair, METEC, International Exhibition for Metallurgical Technology and Equipment; and MINETIME, World Mining Technology Exhibition.

Together, these shows are expected to attract 100,000 trade visitors to Düsseldorf.

33 METAL PRODUCING

#638
Cleveland, Ohio

3T TRUE TEMPERATURE TECHNOLOGIES

#838
Misgav, Israel

3T specializes in the remote measurement of target temperatures. Using unique pyrometers for the temperature measurement of liquid and solid metals including aluminum and steel in extrusion, heat treatment, forging and rolling processes. 3T technology offers greater accuracy resulting in increased productivity and improved quality that translates into cost savings. 3T's unique pyrometers can measure targeted surface temperatures through smoke, dust and water vapor as well as measure the temperature of targets with variable emissivity. In addition, 3T can meet the specialized needs of individual customers.

THORPE TECHNOLOGIES

#732, 734
Whittier, California

U

UNIFRAX CORPORATION-FIBERS DIVISION

#743, 841
Niagara Falls, New York

Unifrax Corporation (formerly known as The Carborundum Company) is one of the leading producers of high performance, heat-management materials used by many industries in a diverse group of applications.

Unifrax is committed to solving industrial insulating problems and providing exceptional value to its customers. This commitment is evident in the company's investment in advanced process technology, its state-of-the-art manufacturing facilities, its extensive research and development activities, and its continual focus on quality in the broad range of products and services it offers.

Fiberfrax insulating products are available in more than 50 product forms. They have traditionally been used in heat vessels in the production and processing of ferrous and non-ferrous metals, industrial chemicals, petroleum products, power generation, and ceramic, glass, and other industries employing process temperatures up to 3000 degrees Fahrenheit (1650 degrees Celsius).

Unifrax will exhibit one of their latest product developments, Insulfrax Specialty Glass Fiber at the upcoming TMS show in February '98. Insulfrax Specialty Glass Fiber is an evolutionary breakthrough in insulating materials, resulting in a product with a wide range of applications in the primary metals and metals processing industries and possessing superior thermal and mechanical properties.

U.S. DEPARTMENT OF ENERGY

#1213
Golden, Colorado

V

VANDEMARK METALS & ALLOYS

#835, 837
Lockport, New York

VAW ALUMINUM

#1133
Bonn, Germany

VAW Aluminum Technologie GmbH (VAW-ATG), a subsidiary of VAW Aluminum AG, is specialized in tailor-made modernization projects for aluminum smelters. The core competencies of VAW-ATG comprise process modeling, process control and data acquisition/data processing, aluminum and carbon technology, casthouse technology and technical engineering.

ELAS - our proprietary Electrolysis Automation System for the process control of aluminum reduction cells - will be presented. This

state-of-the-art distributed control system can be adapted to different cell design and integrated into existing data processing environments. The control algorithms used guarantee maximum productivity and minimum emissions of superfluorinated carbon compounds. ELAS incorporates a central window-oriented information.

VESUVIUS FOUNDRY GROUP

#804, 806
Buffalo, New York

W

WAGSTAFF, INC.

#522
Spokane, Washington

Wagstaff, Inc. manufactures casting equipment for the aluminum industry worldwide. Known for industry breakthroughs in ingot and billet casting systems, as well as automation systems, Wagstaff continues to bring new ideas and equipment to the marketplace.

The precision machined Wagstaff MaxiCast™ Hot Top Billet Casting System maximizes the number of billets that can be cast in the casting pit.

Wagstaff rolling ingot molds have long been the industry standard. The Wagstaff LHC™ Low Head Composite system produces Ingot quality comparable to Electro Magnetic Casting.

Wagstaff AutoCast™ Automated Casting Control Systems allow operators to maintain precise control over the many variables of a cast.

Over fifty years of solid business growth, ISO 9001 certification, and continuing research and development all add up to Wagstaff's commitment to quality and continuous improvement. Call or email for more information 1-(800) 835-8572 or info@wagstaff.com.

WAHL REFRACTORIES, INC.

#933, 935
Fremont, Ohio

WESTERN INDUSTRIAL CERAMICS

#1238
Tualatin, Oregon

WHEELABRATOR AIR POLLUTION CONTROL, INC.

#1112
Pittsburgh, Pennsylvania

E-mail: apcsales@wap.com
Internet: <http://www.wap.com>

Wheelabrator is a global leader in providing pre-engineered and custom-engineered air pollution control systems and services for a wide variety of applications, such as anode bake ovens, pot lines, shredders, delacquar kilns, reverber or induction furnaces, dross cool-

ers and material handling. Our full range of state-of-the-art technologies includes fabric filters, electrostatic precipitators, wet or dry scrubbers, NO_x emission control, and pre-coat systems. We, also, offer process analysis, system design, erection, start-up and complete aftermarket services. As a single-source supplier with almost a hundred years of experience, Wheelabrator can provide its customers with the right technology to meet their specific air quality control requirements.



Wheelabrator
Air Pollution Control

ROYAL TRACTOR COMPANY, INC.

Booth 832
New Century, KS

Royal will present a graphic display which will include Specialized Hauling Equipment with capacities from 25 to 200-tons designed to transport coils, slag, molten metal and other materials. The display will also include Royal's Industrial Lift Truck line of cushion tired lift trucks with capacities from 15,000 lbs (6,803 kgs) to 80,000 lbs. (36,287 kgs), and pneumatic tired lift trucks with capacities from 25, 000 lbs (11,340 kgs) to 55,000 lbs (24,948 kgs). John Pink, Sales Manager-Specialized Hauling Equipment will be at the booth. Please stop by and say hello.